Masters Theses

Student Theses and Dissertations

1947

The effect of temperature on mine rocks

James Wilson Snider

Follow this and additional works at: https://scholarsmine.mst.edu/masters_theses

 Part of the [Mining Engineering Commons](#)

Department: Mining and Nuclear Engineering

Recommended Citation

Snider, James Wilson, "The effect of temperature on mine rocks" (1947). *Masters Theses*. 6668.
https://scholarsmine.mst.edu/masters_theses/6668

This thesis is brought to you by Scholars' Mine, a service of the Curtis Laws Wilson Library at Missouri University of Science and Technology. This work is protected by U. S. Copyright Law. Unauthorized use including reproduction for redistribution requires the permission of the copyright holder. For more information, please contact scholarsmine@mst.edu.

THE EFFECT OF TEMPERATURE ON MINE ROCKS

BY

JAMES W. SNIDER

A

THESIS

submitted to the faculty of the
SCHOOL OF MINES AND METALLURGY OF THE UNIVERSITY OF MISSOURI
in partial fulfillment of the work required for the

Degree of

MASTER OF SCIENCE IN MINING ENGINEERING

Rolla, Missouri

1947

MSM
HISTORICAL
COLLECTION

Approved by

J. D. Forester

Chairman, Department of Mining Engineering

TABLE OF CONTENTS

	Page
Acknowledgements	ii
List of illustrations	iii
List of tables	iv
Introduction	1
Review of literature	3
Determination of coefficient of thermal expansion	8
Preparation of samples	9
Furnace and accessories	9
Calibration tests	12
Test procedure	13
Results	13
Determination of the percent permanent elongation	28
Permanent elongation tests	29
Results	29
Determination of porosity	32
Test procedure	33
Results	35
Determination of permeability	39
Permeability tests	39
Results	43
Conclusions	45
Appendix A	48
Bibliography	50

ACKNOWLEDGEMENTS

The writer wishes to express his appreciation to Dr. J. D. Forrester, Chairman of the Department of Mining Engineering, for suggesting the problem and for his consultation and advice given during this investigation.

The author is also indebted to Dr. P. G. Herold, Professor of Ceramic Engineering, to Mr. F. A. Graser, Associate Professor of Petroleum Engineering, to Mr. K. E. Born, Assistant Professor of Geology, and to Mr. T. J. Planje, Instructor in Ceramic Engineering for their advice on one or more phases of this investigation.

Acknowledgements are also due to the Department of Mechanical Engineering for the construction of the furnace equipment and the use of measuring instruments, and to Mr. Walter Lewis who gave assistance in preparation and collection of the samples.

LIST OF ILLUSTRATIONS

Figure		Page
1	Furnace and accessories	8a
2	Temperature gradient in the furnace	12a
3	Current and heating rate relationship	12b
4	Schematic diagram of permeability testing apparatus	41
Plate		
I.	Thermal expansion curve, SANDSTONE	17
II.	Thermal expansion curve, SANDSTONE	18
III.	Thermal expansion curve, DOLOMITE	19
IV.	Thermal expansion curve, DOLOMITE	20
V.	Thermal expansion curve, LIMESTONE	21
VI.	Thermal expansion curve, LIMESTONE	22
VII.	Thermal expansion curve, DOLOMITE	23
VIII.	Thermal expansion curve, SANDSTONE	24
IX.	Thermal expansion curve, SHALE	25
X.	Thermal expansion curve, GRANITE	26
XI.	Thermal expansion curve, PORPHYRY	27
XII.	Permanent elongation curves	30

LIST OF TABLES

Table		Page
I.	Coefficients of thermal expansion arranged according to percentages of silica	4
II.	Average coefficients of linear-thermal expansion of rocks from various sources	7
III.	Samples data sheet used for thermal expansion tests	15
IV.	Data sheet for porosity tests	36
V.	Data sheet for permeability tests	44
VI.	Tabulated results	47

INTRODUCTION

The problem of this investigation involves the determination of the coefficients of thermal expansion of mine rocks, and the relationship of porosity, permeability, and consecutive temperature changes to the permanent elongation of those rocks.

One of the major problems in mining today is that of the analysis of the action of exposed mine rock under changes of temperature. The immediate cause of a fall of ground in a mining excavation is due to the fact that some part of the mass that falls has been subjected to a stress beyond the strength of the rock. The question arises as to what changes occur in these exposed rock masses to cause the rock to fall. Frequent temperature changes may be one of the causes.

The exposed rock of the roof contracts and expands with changes in temperature of the air in the mine. Stresses are applied to a rock as a result of the changes in temperature, and strains develop as a result of the contraction and expansion. The rock will crack and slough when the amount of total stress applied to it exceeds the breaking strength of the rock.

The values of the coefficient of thermal expansion established in this investigation may be applied to rocks of the types tested here. The amount of movement in the rock can be estimated by the use of the values determined.

The effect of consecutive changes in temperature of rocks is also studied in order to determine the relative permanent change in length of a rock in one direction.

The coefficient of thermal expansion and the amount of change in

length of a rock may be governed in some manner by the porosity and the permeability of the rock; therefore, porosity and permeability tests are made to determine whether or not this relationship exists.

Eleven different samples of rock were studied in this investigation, six of which were tested by Lewis^{1/} for mechanical properties.

^{1/} Lewis, W. E., Mechanical properties of mine-rock. Thesis, Missouri School of Mines and Metallurgy, Rolla, Missouri. 1946. 137 pp.

REVIEW OF LITERATURE

A few previous investigations have been made to determine the coefficient of thermal expansion of rock. The purpose of the majority of these was to determine expansion data on the type of rocks used in building practice. In a study by the U. S. Bureau of Mines,^{2/} however, the main

^{2/} Hartman, I., and Greenwald, H.P., Effect of changes in moisture and temperature on mine roof: U.S. Bureau of Mines, Report of Investigations 3588, 1941, 40 pp.

objectives were to determine the relative importance of humidity and temperature changes on the expansion and contraction of mine-roof rock samples of a coal mine, to determine the stresses that might result from these changes, and to correlate this information with the physical properties of the rocks.

^{3/} Griffith, in his investigation, determined the coefficients of expansion

^{3/} Griffith, J. H., Thermal expansion of typical American rocks: Iowa State College Engineering Experiment Station Bulletin 128. 1936. 36 pp.

sion of 100 typical American rocks used for building purposes. The rocks were tested through a moderate range of temperatures which are usually encountered in building practices. He showed the relationship between the average value for expansion coefficients and the percent silica of the different types of rocks (Table I). Griffith used a multiple-unit electric furnace with microscopes to read the expansion of the rock. His samples averaged 4 inches (10 cm.) in length, and the rate of heat application was 200 to 300 Deg. F. (111 to 167 Deg. C.) per hour.

An investigation was carried out by Westman^{4/} to determine the thermal

^{4/} Westman, A. E. R., Thermal expansion of fireclay bricks. University of Illinois Experiment Station Bulletin 181. 1928. 30 pp.

Table I
Coefficients of Thermal Expansion Arranged According to Percentages of Silica*

Type of Rock	Coef. of Thermal Expansion (°F.) Multiply numerals by 10 ⁻⁷	Average from (2)	Equivalent** (°C.)	Percent silica
(1)	(2)	(3)	(4)	(5)
Cherts, quartzites	64,67,61,60,55	61	11.0	94
Sandstones	47,57,37,56,63,55,55,65,51,59	54	9.7	84
Granitoid rocks	41,45,34,49,36,19,47,52,39,38, 66,41,45,29,58,50,56,37,37,60, 37,42,28	43	7.7	66
Slates	49,45,49,35	44	7.9	61
Andesites	23,25,39,57	36	6.5	58
Gabbros, basalts and diabase	26,22,33,26,35,35,31,30,20,50	31	5.6	51

* After J. H. Griffith. page

** The values in Column (4) have been converted by the writer in order that a comparison can be made.

expansion of fireclay bricks, which have average chemical properties approximately the same as those of the different rocks. Westman used a furnace similar in design to the one used by the writer which is described below, and he used a dial gage to measure the increments of increasing length of his specimens. His specimens measured 1 inch in diameter and 9 inches in length. Westman illustrated the variation that exists between the expansion coefficients and the silica and the alumina percentage in fireclay bricks. His values of the coefficients increased as the percent of silica increased, but as the percent of alumina increased the values for the coefficients decreased.

^{5/} Reade determined expansion coefficients of rock by using an ordinary

^{5/} Reade, T. M., The Origin of Mountain Ranges. Philosophical Magazine. 1886.

oven and measuring the length of the specimens with a venier caliper both before and after heating. He took the mean of several readings as his final result, and he presented this value to represent the average expansion for all rock. The lengths of Reade's specimens were approximately 15 inches.

^{6/} Hallock used a comparator method involving the use of a micrometer

^{6/} Hallock, W. Preliminary notes on coefficients of thermal expansion of certain rocks: U. S. Geological Survey, Bulletin 78. 1891. pp. 109-118.

microscope. He heated his specimens in a water bath whose temperature ranged from 20 to 100 Deg. C. He observed that after two or three consecutive heatings a permanent condition was reached in the length of the rock. He also observed in other runs that at a temperature of 100 Deg. C. the length of the rock was practically constant.

An investigation was carried out by Wheeler^{7/} to determine the relative

^{7/} Wheeler, N. E., On the thermal expansion of rock at high temperature: Transactions of the Royal Society of Canada. 3d series. Volume IV. 1910. pp. 19-44

expansion of a certain nickel-steel alloy, and of granite and diabase up to a comparatively high temperature. The specimens used by Wheeler measured 20 cms. in length with a diameter of 2.4 cms. The specimens were heated six times to about 1,000 Deg.C., and the differences in the values of the expansion coefficients for each successive heating were illustrated. Wheeler also illustrated the relationship between the permanent expansion of each specimen after each heating and the number of consecutive heatings.

Table II
Average Coefficients of Linear Thermal Expansion of Rocks from Various Sources
(Range from °C. to 100°C.)

Coefficients of thermal expansion (multiply numerals by 10 ⁻⁶)						Authority
Granite (1)*	Limestone (2)*	Sandstone (3)*	Slate (4)*	Porphyry (5)*		
7.9	7.9	9.7	8.1	5.5		Griffith (a)
7.2	8.1	9.9	10.6			Merriman (b)
6.5	5.0	9.4	9.4			U.S. Arsenal (c)
8.9						Reade (d)
		17.1	8.7			Bartlett (e)
9.1						Wheeler (f)
		9.2	7.4			U. S. Bureau of Mines (g)

*These values have been converted by the writer to expansion expressed per degree centigrade.

(a) Griffith, J. H., op.cit., p. 27.

(b) Merriman, M., ed. American Civil Engineers' Pocket Book. 1st ed., John Wiley & Sons, Inc., New York. 1911

(c) Withey, M. O., and Aston, J. Johnson's Materials of Construction. 7th ed., p. 614. John Wiley & Sons, New York. 1930.

(d) Reade, W., op.cit.

(e) Bartlett, W. H. C., op. cit.

(f) Wheeler, N. E., op. cit.

(g) Hartman, I., and Greenwald, H. P., op. cit., p. 20

DETERMINATION OF COEFFICIENTS OF THERMAL EXPANSION

The coefficient of thermal expansion of a substance is expressed as the increase in length per unit length per degree rise in temperature. This coefficient has different values for different substances, and for a given substance it varies somewhat over different temperature ranges. It is expressed in units of the English system as inches per inch per degree Fahrenheit, and in the metric system is expressed as centimeters per centimeter per degree centigrade. The metric system is used in expressing the values determined in this analysis.

The apparatus used to make the temperature tests of this investigation is shown in Figure 1, and it is also described below. The test procedure described below is a relatively simple method and was suggested to the writer by Dr. P. G. Herold.* More precise measurements on smaller specimens

* Personal Communication Dr. P. G. Herold, Professor of Ceramic Engineering, Missouri School of Mines and Metallurgy, Rolla, Missouri.

using an interferometer might present a more exact approach to the problem, but two groups of observers at the National Bureau of Standards^{8/} working

^{8/} Souder, W. H., and Hidnert, P., Measurements on the thermal expansion of fused silica, National Bureau of Standards, Scientific Paper No. 524, Washington, D. C. 1927.

independently and simultaneously on the same materials found the resulting curves for expansion coefficients were practically identical by either dial gage or interferometer, and that certain advantages in one are compensated by those in the other.

The temperature range of the thermal expansion tests is between 0 and 200 Deg. C. (32 to 392 Deg. F.). The values for the coefficient of thermal expansion for each sample are calculated from observed readings. Two values

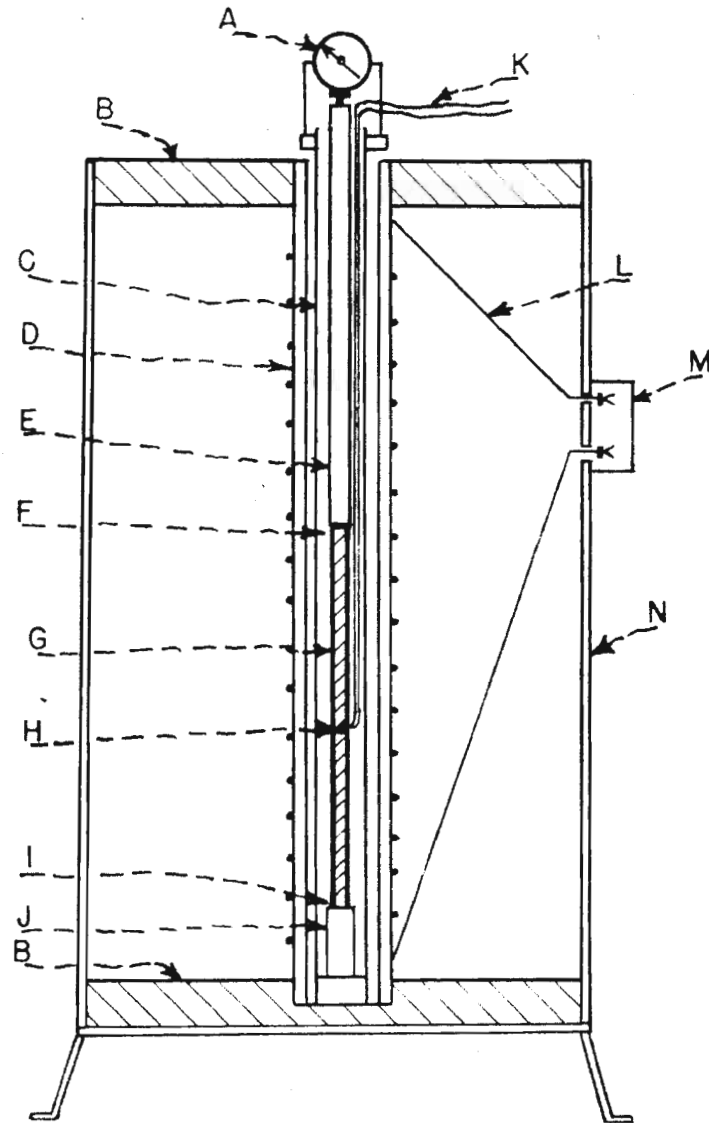

- | | |
|---------------------------|----------------------------|
| A Dial gage and support | H Thermocouple junction |
| B Transite Insulation | I Area at base of specimen |
| C Vitreous silica saddle | J Vitreous silica pedestal |
| D Alundum core | K Thermocouple leads |
| E Vitreous silica rod | L Nichrome V wire winding |
| F Area at top of specimen | M 110 volt A.C. supply box |
| G Specimen | N Steel cylinder |

Figure 1. -- FURNACE AND ACCESSORIES

are determined: the first, between 0 and 100 Deg. C.; the second, between 100 and 200 Deg. C.

Preparation of Samples

All specimens are prepared for testing by cutting them to uniform sizes (6 to 9 in. in length with a cross-section approximately $\frac{3}{8}$ by $\frac{3}{8}$ in.), parallel to the bedding plane in the sedimentary rocks. Samples of rocks that appear to be comparatively free from joints and fractures are selected for the tests. The harder rocks are broken by a hammer and chisel to dimensions that can be easily handled on the platform of a Felker DI-Met cutting machine*, and the softer rocks are first cut with a hack saw.

* Felker Manufacturing Company, Torrance, California.

The cutting machine is equipped with an 8-inch diameter DI-Met Rimlock blade. The careful preparation of each specimen is an important factor in governing the reliability of test data.

A hole, 0.06 inches in diameter, is drilled into the side of each specimen at the center to provide a place for the insertion of a thermocouple hot junction.

The end faces of each specimen are ground flat with carborundum dust, and the working lengths of the specimens are measured with a vernier caliper reading to 0.01 inches. These measurements are converted to centimeters.

Furnace and Accessories (Figure 1)

An 18-inch externally wound electric tube furnace was designed for this investigation to operate at 110 A.C. through a temperature range of 500 Deg. C.

The outer shell of the furnace has a 10 $\frac{5}{8}$ inch outside diameter, 18 $\frac{3}{4}$ inch length, and is made of $\frac{1}{4}$ inch steel. Insulation is provided at the top and bottom by a circular piece of 1-inch transite. Diatomaceous

earth was used to insulate the alundum core* and the winding from the out-

* Norton Company, Worcester, Massachusetts

side wall.

A simple electric circuit consists of a Weston ammeter (0 to 5 amps), a variable rheostat, and the Nichrome V wire** heating element wound around

** Driver-Harris Company, Harrison, New Jersey.

the Alundum core.

A chromel-alumel thermocouple was used in conjunction with a Leeds and Northrup potentiometer indicator*** reading in millivolts. This potenti-

*** Leeds and Northrup, Inc., Philadelphia, Pennsylvania

meter indicator has an adjustable reference junction compensator; when the potentiometer is used with one of the standard types of thermocouples, the instrument will read directly without adjustment for a reference junction temperature provided that the room temperature is constant. The room temperature remained nearly constant throughout the length of each run and was measured with a standard centigrade thermometer. A conversion table for a chromel alumel thermocouple is used to convert the millivolt readings into degrees centigrade.

A Starrett extensometer* reading to 0.01 mm. is used to measure the

* L. S. Starrett Company, Athol, Massachusetts

increase in length of the rock. This gage is mounted on a support that is clamped to the top of a vitreous silica saddle. This saddle fits inside the core of the furnace and rests on the transite bottom piece. A rod and a pedestal, also made of vitreous silica, are placed above and below the specimen respectively.

Calibration Tests

The first calibration test was made to determine the temperature gradient between the region at the top of the specimen and the region at the base of the specimen (points F and I in Figure 1.). Two calibrated centigrade-thermometers were used to take the readings. The average temperature difference between these two points was 1.9 Deg. C. Figure 2 illustrates graphically this difference. The temperature of the samples was measured at the center of the specimen and should therefore represent the average temperature between the top and bottom of the specimen.

A second test was made to determine the relationship between the amount of current flowing in the heating element and the rate of temperature rise inside the furnace (Figure 3.). The amount of current supplied to the heating element was controlled by the rheostat. A current can be chosen from the graph in Figure 3 and then set by the rheostat to the heating rate desired. A heating rate of approximately 120 Deg. C. per hour is used for all thermal tests in this investigation.

A third test was made to calibrate the thermocouple. The freezing temperatures of a sample of National Bureau of Standards tin, 231.9 Deg.C., and a National Bureau of Standards lead, 327.4 Deg. C., and the boiling point of water at 734.0 mm Hg pressure, 99.03 Deg. C. are used as reference temperatures. The freezing temperatures recorded by the chromel-alumel thermocouple and potentiometer used in this investigation for National Bureau of Standards tin was 231.0 Deg. C.; for National Bureau of Standards lead was 326.2 Deg. C.; and for water at the above mentioned pressure, 98.2 Deg. C.

A fourth test was made to determine the differential expansion between the vitreous silica saddle and the vitreous silica rod and pedestal. It was found that the total differential expansion between these units was 0.0002 centimeter through a temperature range 23 to 200 Deg. C. The effect

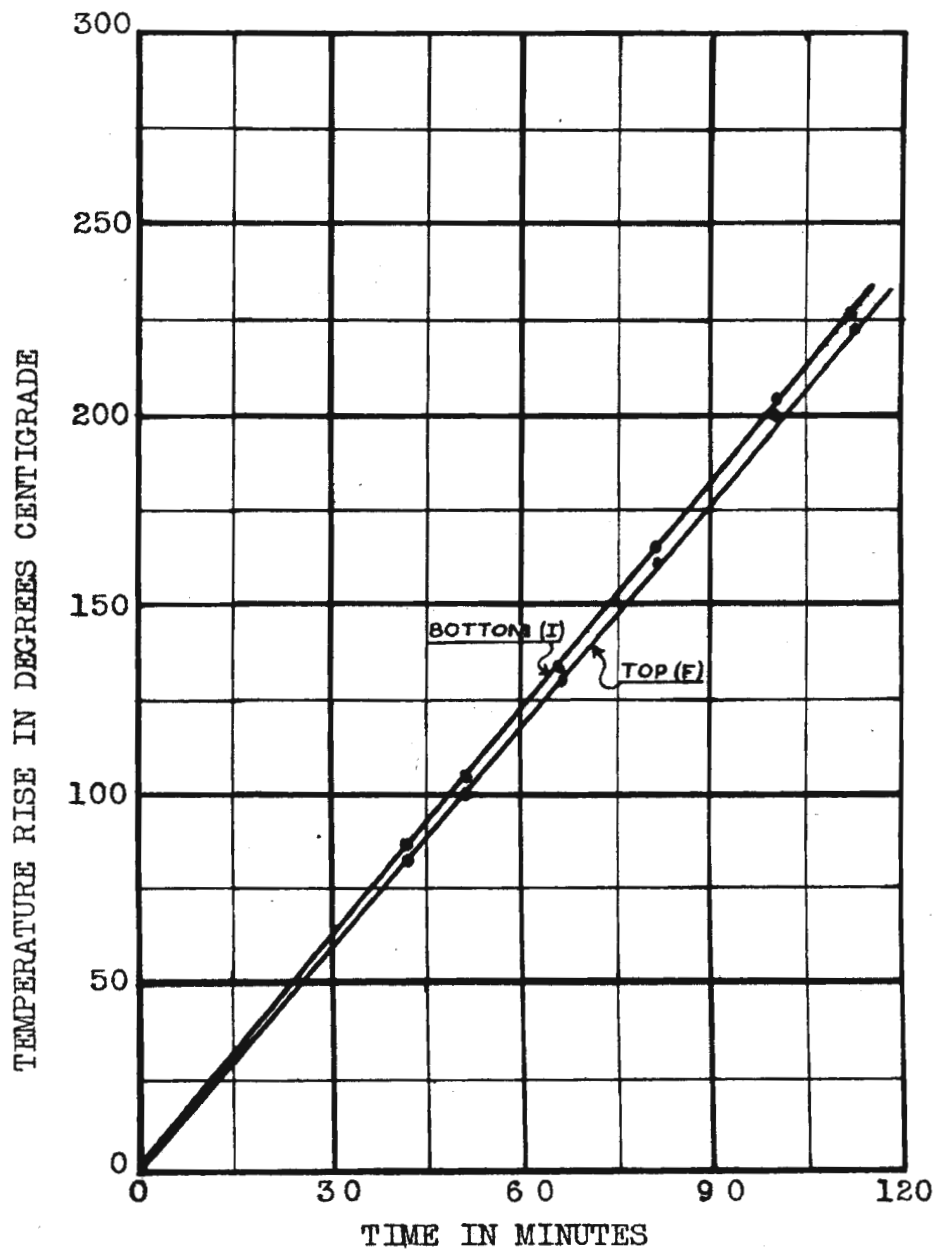

Figure 2. -- TEMPERATURE GRADIENT IN THE FURNACE

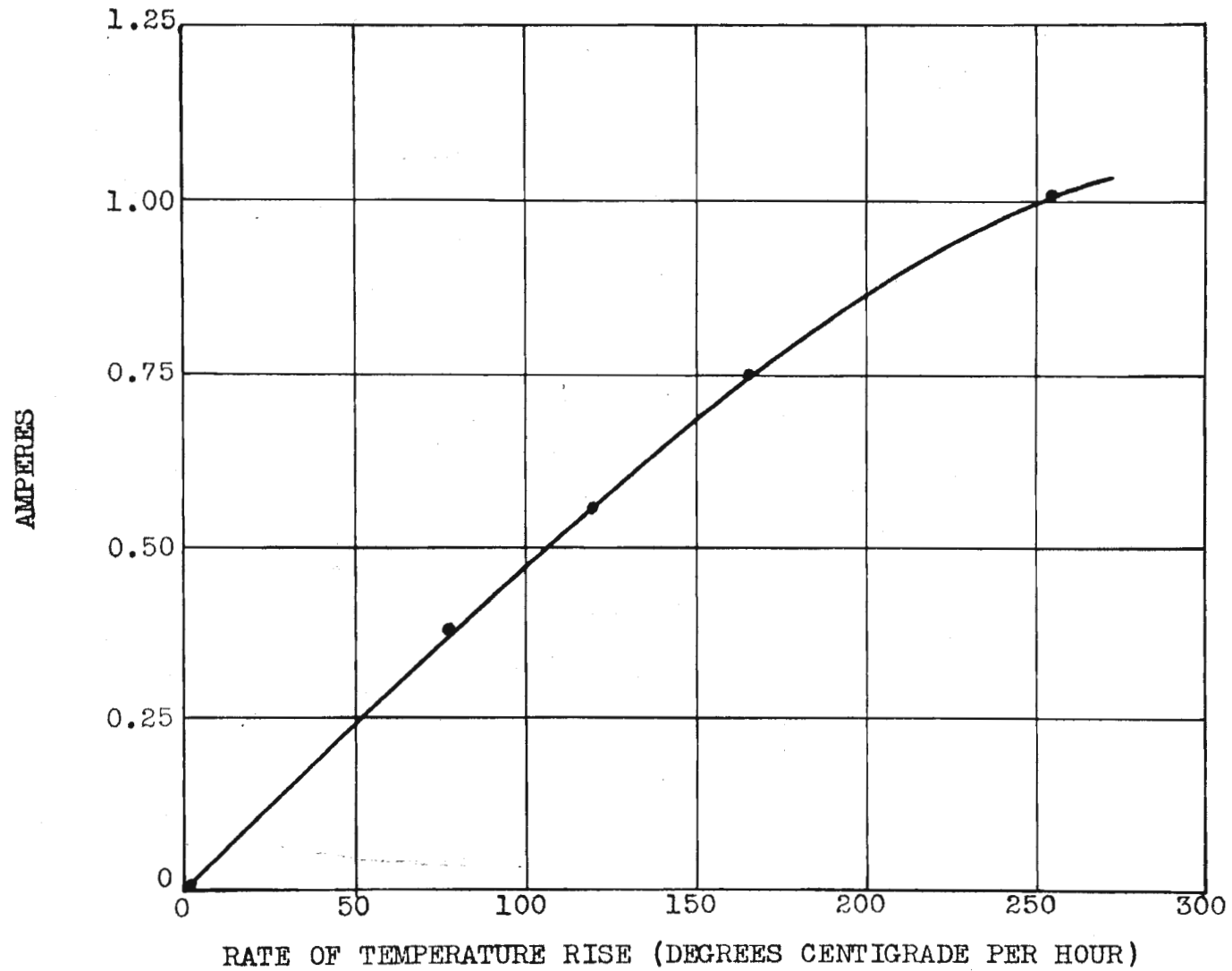

Figure 3. --CURRENT AND HEATING RATE RELATIONSHIP

of this differential expansion is considered negligible in this study and therefore no attempt is made to apply correction for this small amount of error.

Test Procedure

The specimens are placed in an insulated container with solid carbon dioxide (dry ice) for a period of 8 hours. The specimen is then removed from the container and the hot junction of the thermocouple is inserted into the hole provided for it as described above. The specimen is then placed on top of the pedestal inside the saddle. The vitreous silica rod is then placed on top of the specimen and the extensometer is adjusted to zero.

Heat is applied at the rate of 120 Deg. C. per hour. Expansion readings from the extensometer dial are taken every 20 degree rise in temperature through the 200 degree temperature range. The first reading at 0 degrees is the zero expansion reading. Measurements were recorded on a data sheet an example of which is shown in Table III.

Inasmuch as the original length of the specimen at room temperature is known, the percentage of expansion for each 20 degree interval can be calculated. This percentage of expansion is platted as the ordinate and the corresponding temperature reading is platted as the abscissa. The slope of a line drawn through these points represents the coefficient of expansion of that particular specimen within the temperature range desired.

Results

The values for the coefficient of expansion of each sample tested are tabulated in Table VI. Two expansion coefficients were calculated for each sample: the first, between 0 and 100 Deg. C.; and the second, between 100 and 200 Deg. C.

The sandstones (samples 4, 12, and 20), as a group, have the highest coefficients both in the low range (0 to 100 Deg. C.) and in the high range (100 to 200 Deg. C.) of temperature. The average coefficient for these three sandstone samples in the low range is 10.12×10^{-6} . From Table II it is seen that the coefficient of expansion of sandstone as found by other investigators ranges from 9.2 to 17.1 with the average about 9.5×10^{-6} . Plates I, II, and VIII are the thermal expansion curves for these three samples.

The dolomites (samples 14, 15, and 19) have relatively lower expansion coefficients than the sandstones in both the low range and the high range. The average coefficient for these three dolomite samples in the low range is 8.69×10^{-6} . The writer was unable to find data on the expansion of dolomite from previous investigations, therefore, no comparison can be made. Sample 15, however, contains chert which may have caused this dolomite to have a larger coefficient than the dolomites 14 and 19.

The limestones (samples 17 and 18) have comparatively low coefficients within the low range, but have an average coefficient in the high range nearly equal to that of sandstones. The low range coefficients average 7.71. The average coefficients for limestones found by other investigators (Table II) is 7.0×10^{-6} .

The shale (sample 22) has a coefficient of 8.36×10^{-6} within the low range, and within the high range it has the lowest coefficient, 9.53, of all the samples tested in this range.

The granite (sample 23) has the lowest coefficient within the low range of any sample tested. The low range coefficient is 6.27×10^{-6} and the high range coefficient is 11.03×10^{-6} which is nearly double the former.

Other investigators (Table II) have found relatively higher coefficients

Table III
Sample Data Sheet Used for Thermal Expansion Tests

Length 17.389 cm.
Room temperature: Before 23°; After 23°C.

Sample Number 23

Time	Amps.	Dial Read.	Increment percent increase	Temperature (°C.)	M.V.
0 min.	0.55	0.000	0.000000	0.0	0.0
5	0.55	0.007	0.000040	10.0	
10	0.55	0.014	0.000080	20.0	
21	0.55	0.032	0.000184	40.0	1.61
31	0.55	0.055	0.000316	60.0	2.43
41	0.55	0.079	0.000450	80.0	3.26
51	0.55	0.109	0.000627	100.0	4.10
61	0.55	0.141	0.000810	120.0	4.92
72	0.55	0.174	0.001002	140.0	5.33
82	0.55	0.210	0.001207	160.0	6.53
92	0.55	0.251	0.001441	180.0	7.33
102	0.55	0.301	0.001733	200.0	8.13

for granite within the low range, but the values they found range from 6.5 to 9.1.

The porphyry (sample 24) is similar to the granite in that the coefficient of each are nearly equal in both the low and the high range.

Buckley^{9/} points out that each mineral in a rock has a different rate

^{9/} Buckley, E. R., Building and ornamental stones: Wisconsin Geological and Natural History Survey, Bulletin IV. 1898. pp. 18-19.

of expansion, and that igneous rocks are usually composed of several different minerals interlocking with one another, while sedimentary rocks consist mainly of one mineral. For these reasons, the unmodified sedimentary rocks are usually less injured by frequent changes in temperature, and when a rock is heated each particle will press unequally against the adjacent particle. When the rock is cooled, stresses are set up, due to contraction, which tend to pull the individual particles apart. Likewise, due to the inequalities in the rate of expansion in the different mineral particles, stresses are initiated, in rocks having a heterogenous composition, which tend not only to rupture the individual particles but also to separate them from the adjacent particles. The result of these changes in temperatures, besides weakening the rock, is to produce small cracks and joints.

Of all the specimens tested there was no evidence of cracks or joints as far as could be observed megascopically.

PLATE I, THERMAL EXPANSION CURVE, SANDSTONE (4)

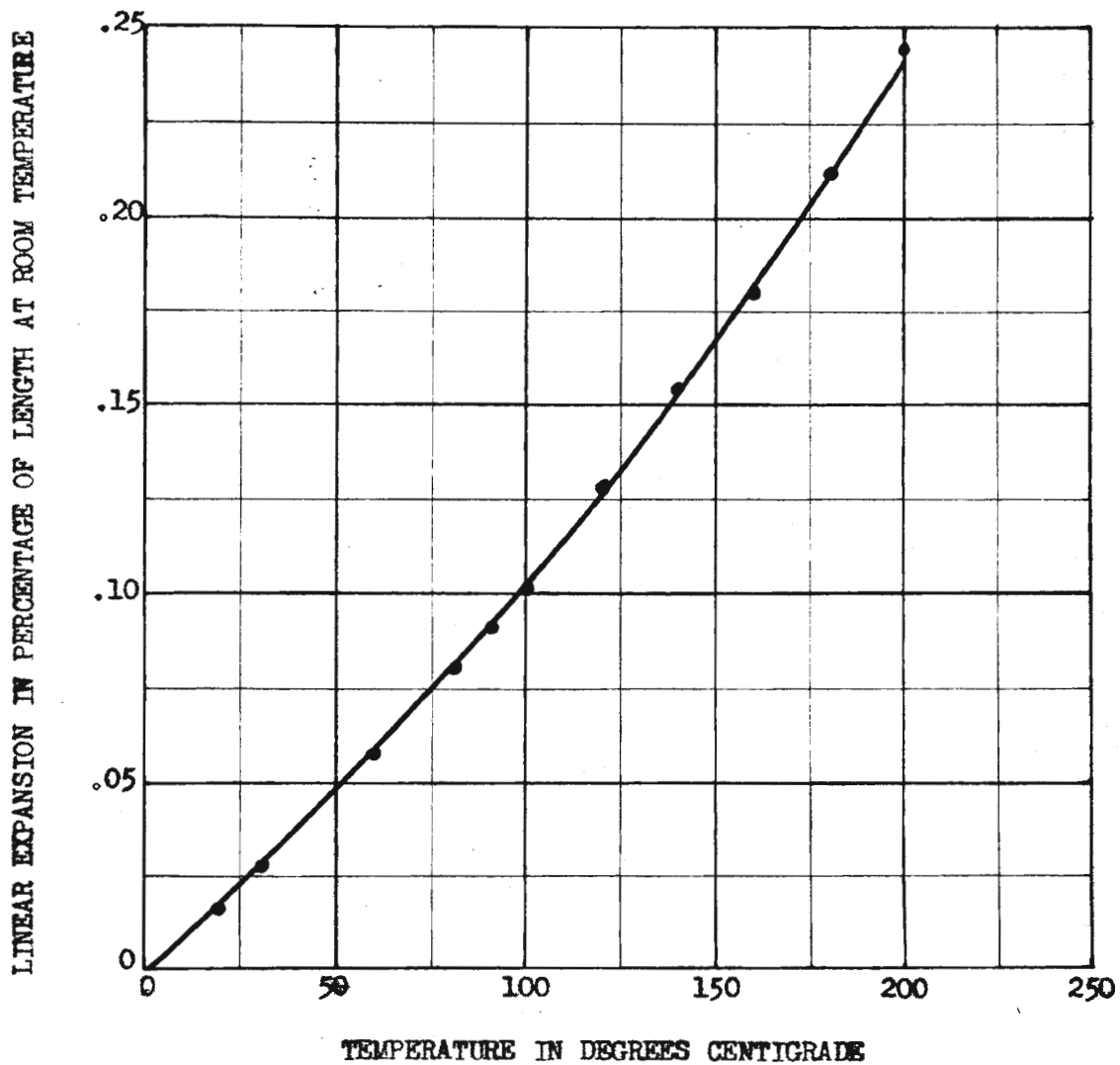

Expansion coefficient 0 to 100 Deg.C. = 10.39×10^{-6}

Expansion coefficient 100 to 200 Deg.C. = 14.16×10^{-6}

PLATE II, THERMAL EXPANSION CURVE, SANDSTONE (12)

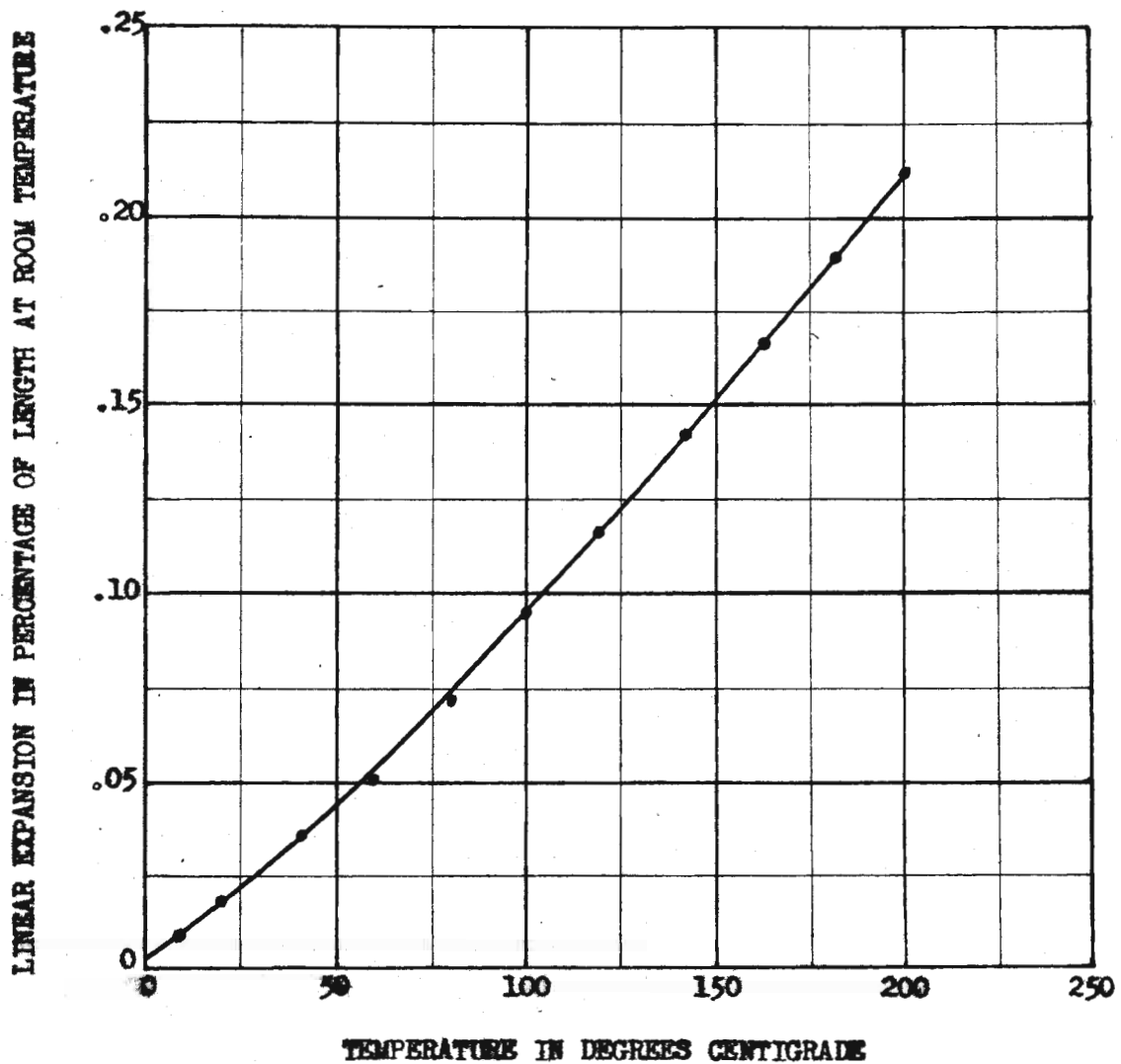

Expansion coefficient 0 to 100 Deg.C. = 9.36×10^{-6}

Expansion coefficient 100 to 200 Deg.C. = 11.54×10^{-6}

PLATE III, THERMAL EXPANSION CURVE, DOLOMITE (14)

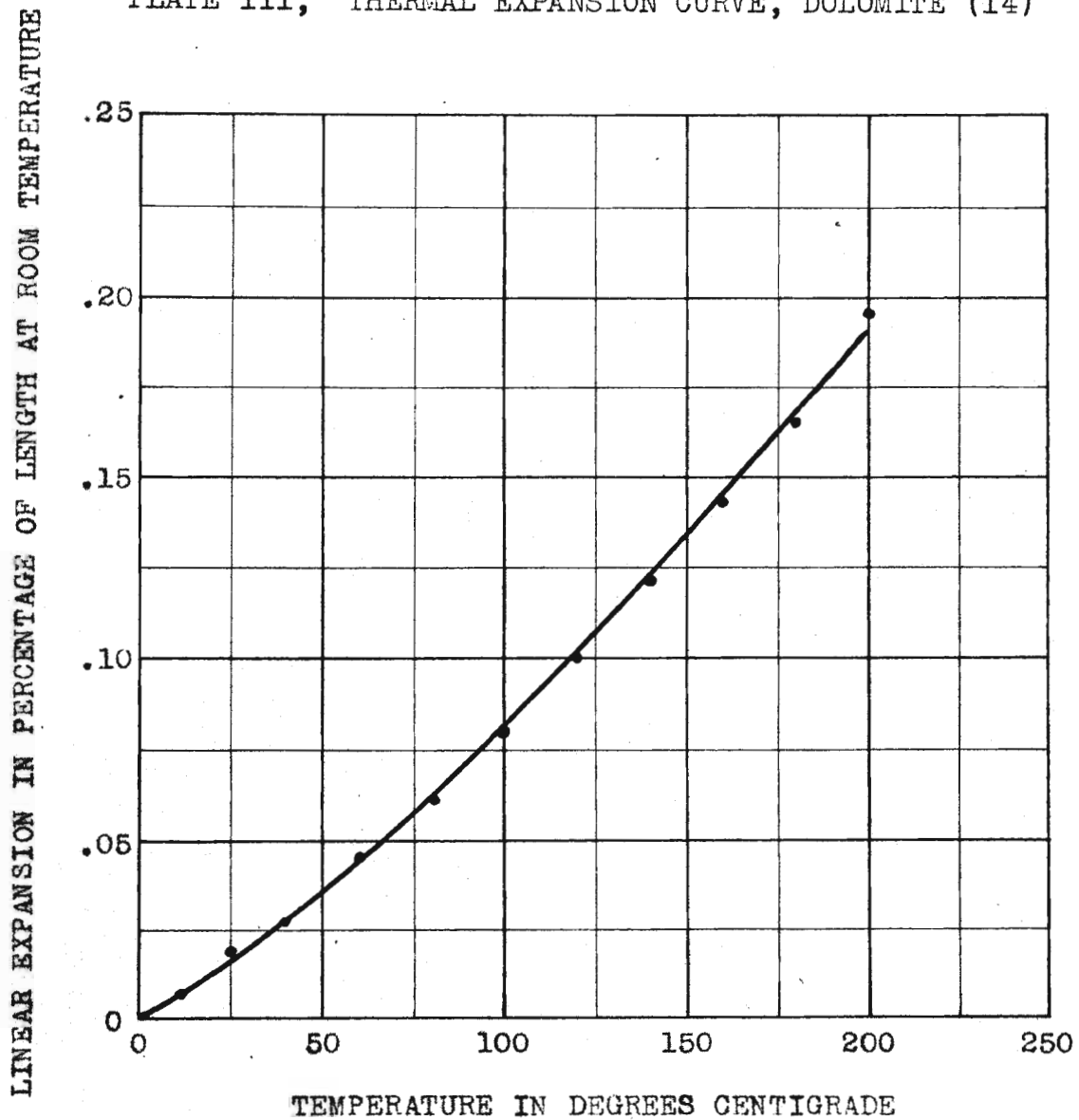

Expansion coefficient 0 to 100 Deg.C.= 8.00×10^{-6}

Expansion coefficient 100 to 200 Deg.C.= 11.64×10^{-6}

PLATE IV, THERMAL EXPANSION CURVE, DOLOMITE (15)

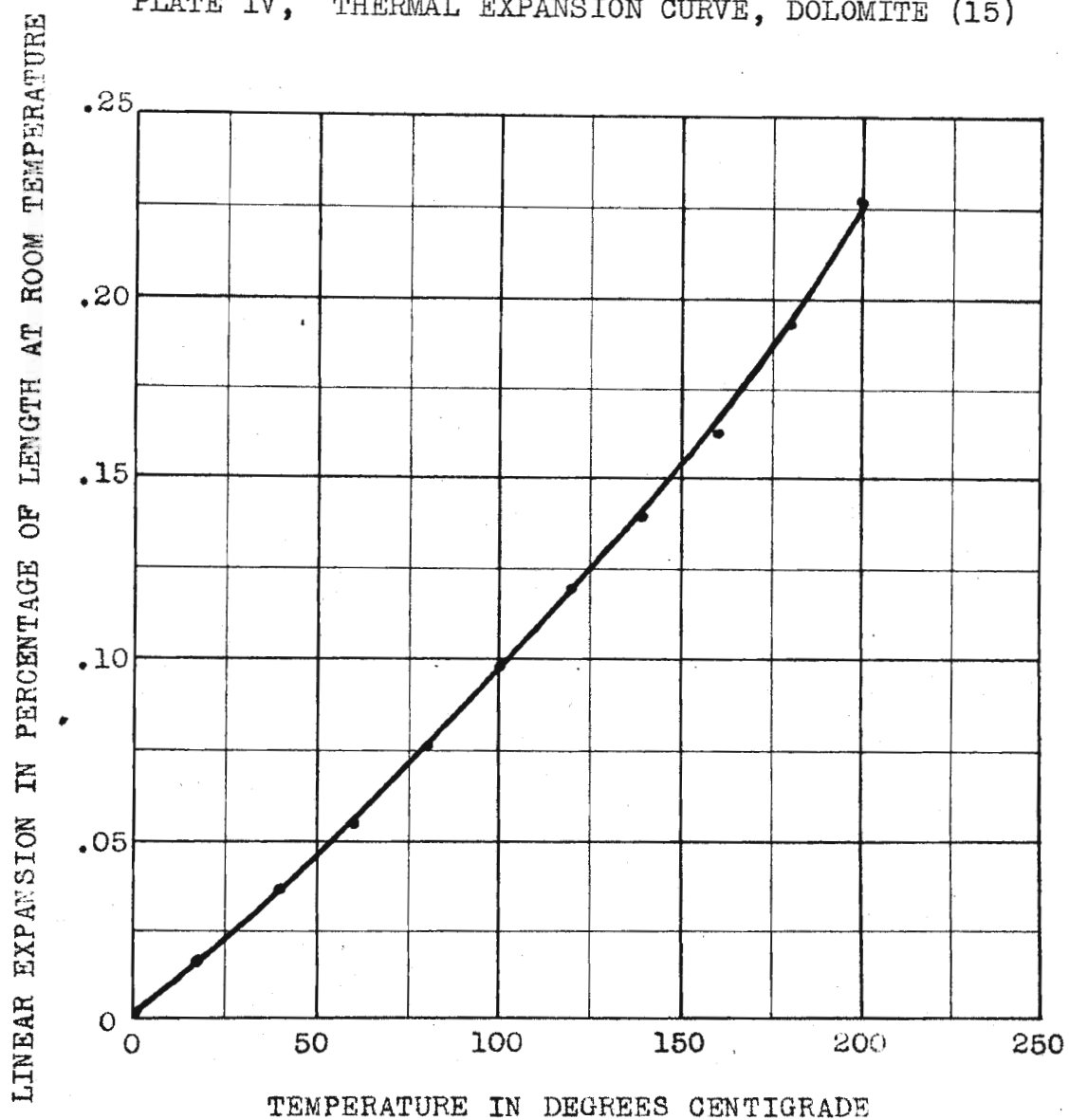

Expansion coefficient 0 to 100 Deg.C.= 9.80×10^{-6}

Expansion coefficient 100 to 200 Deg.C.= 12.80×10^{-6}

PLATE V, THERMAL EXPANSION CURVE, LIMESTONE (17)

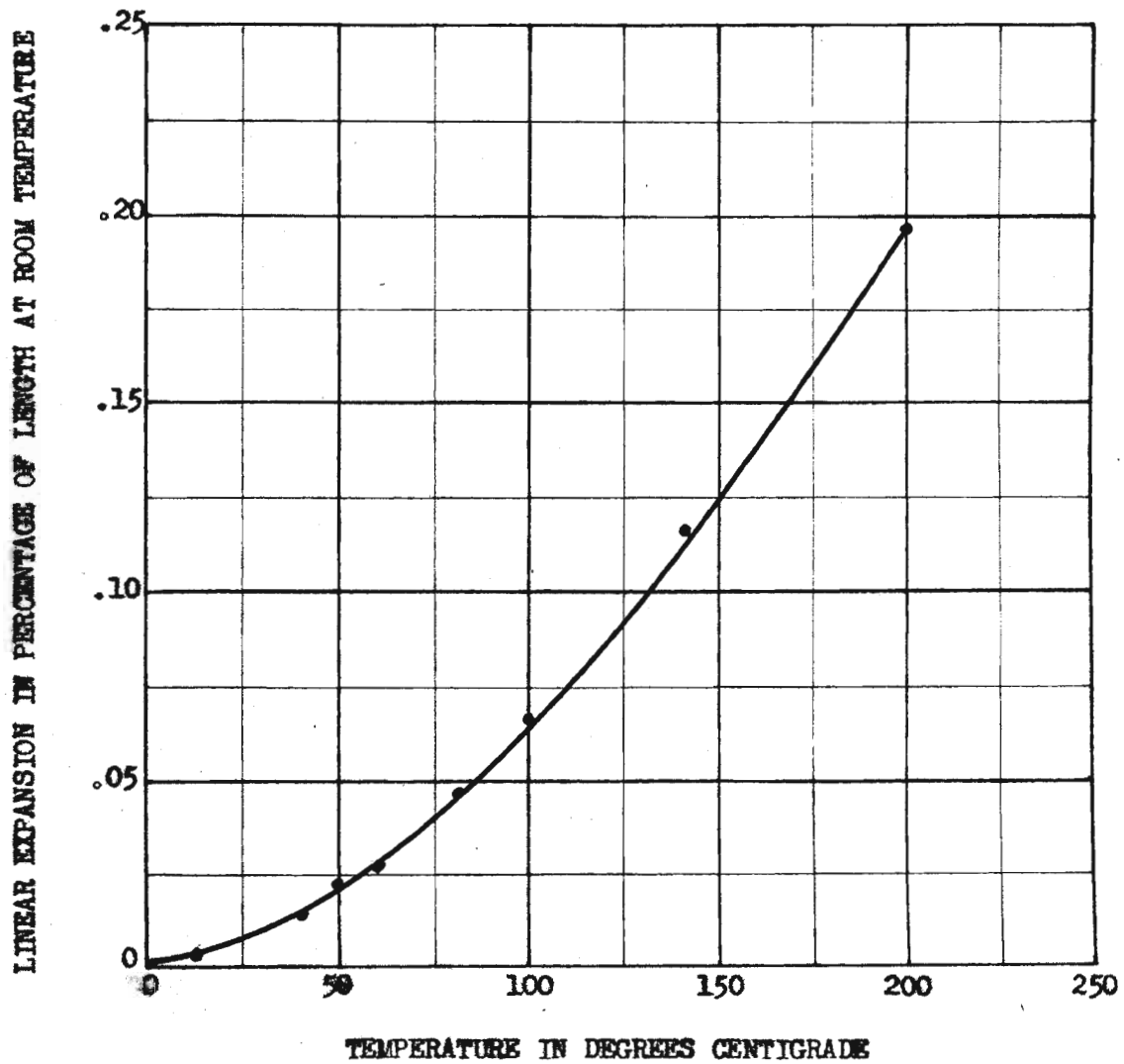

Expansion coefficient 0 to 100 Deg.C. = 6.62×10^{-6}

Expansion coefficient 100 to 200 Deg.C. = 12.93×10^{-6}

PLATE VI, THERMAL EXPANSION CURVE, LIMESTONE (18)

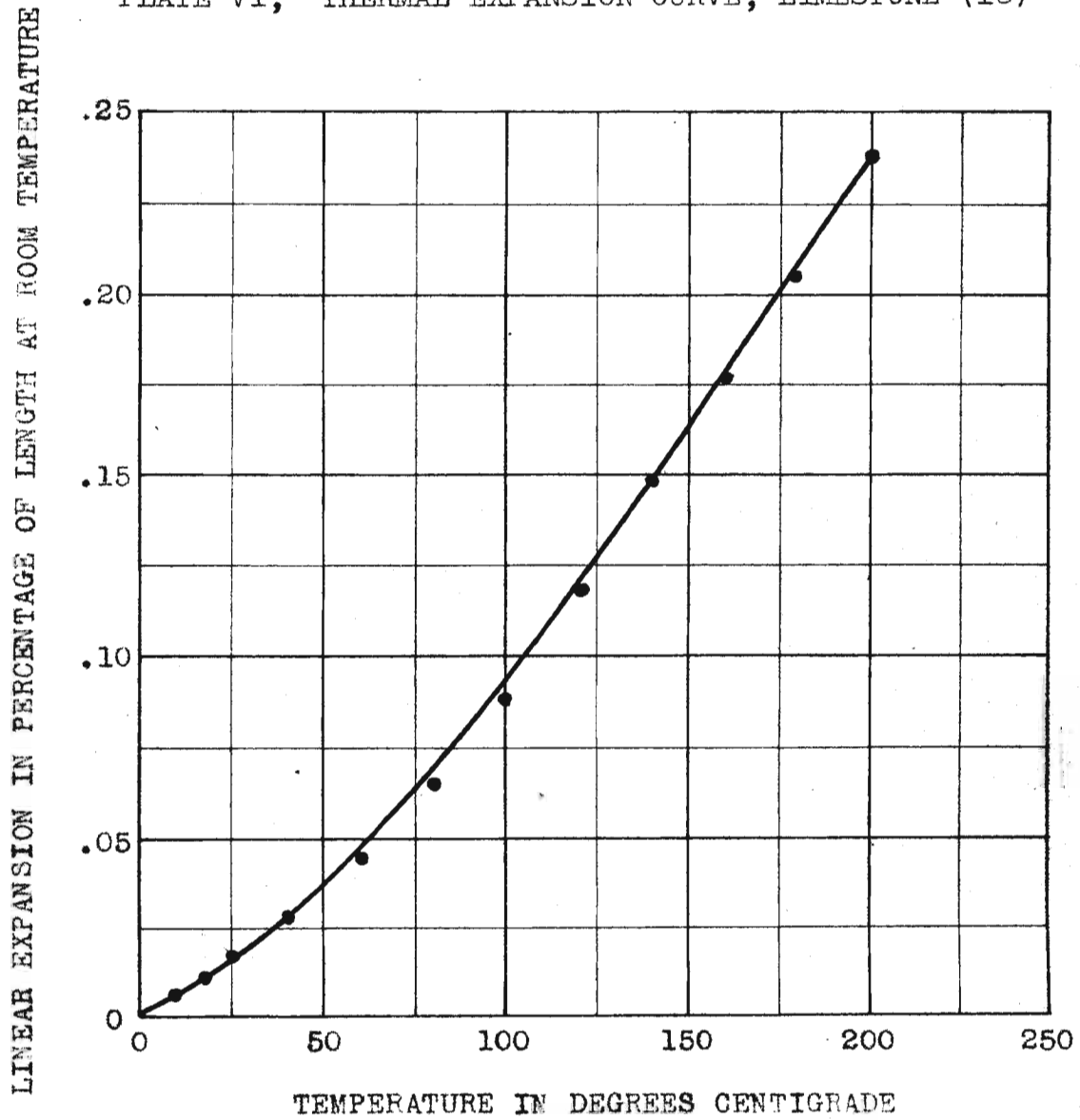

Expansion coefficient 0 to 100 Deg.C.= 8.80×10^{-6}

Expansion coefficient 100 to 200 Deg.C.= 14.95×10^{-6}

PLATE VII, THERMAL EXPANSION CURVE, DOLOMITE (19)

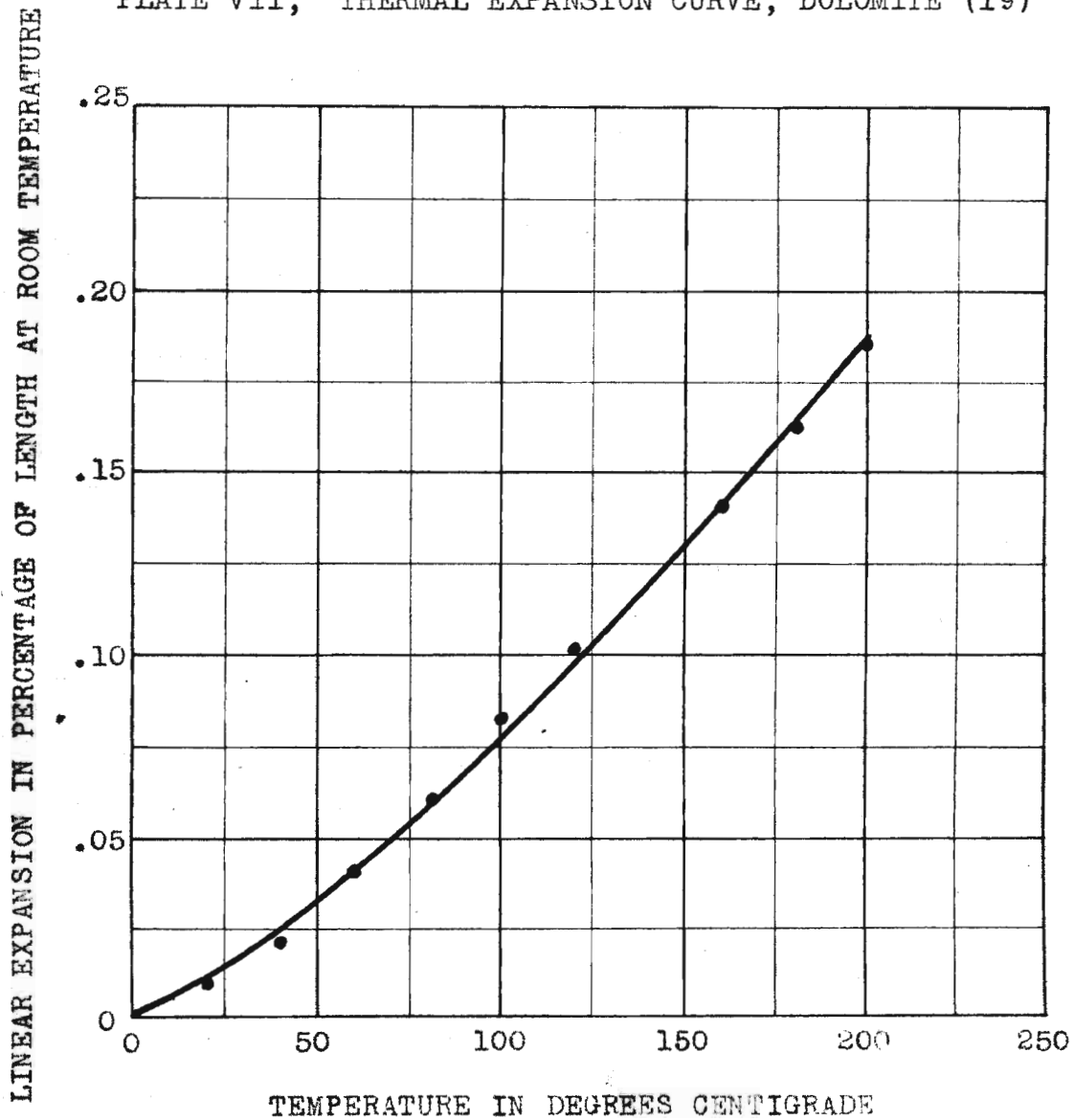

Expansion coefficient 0 to 100 Deg.C.= 8.28×10^{-6}

Expansion coefficient 100 to 200 Deg.C.= 10.12×10^{-6}

PLATE VIII, THERMAL EXPANSION CURVE, SANDSTONE (20)

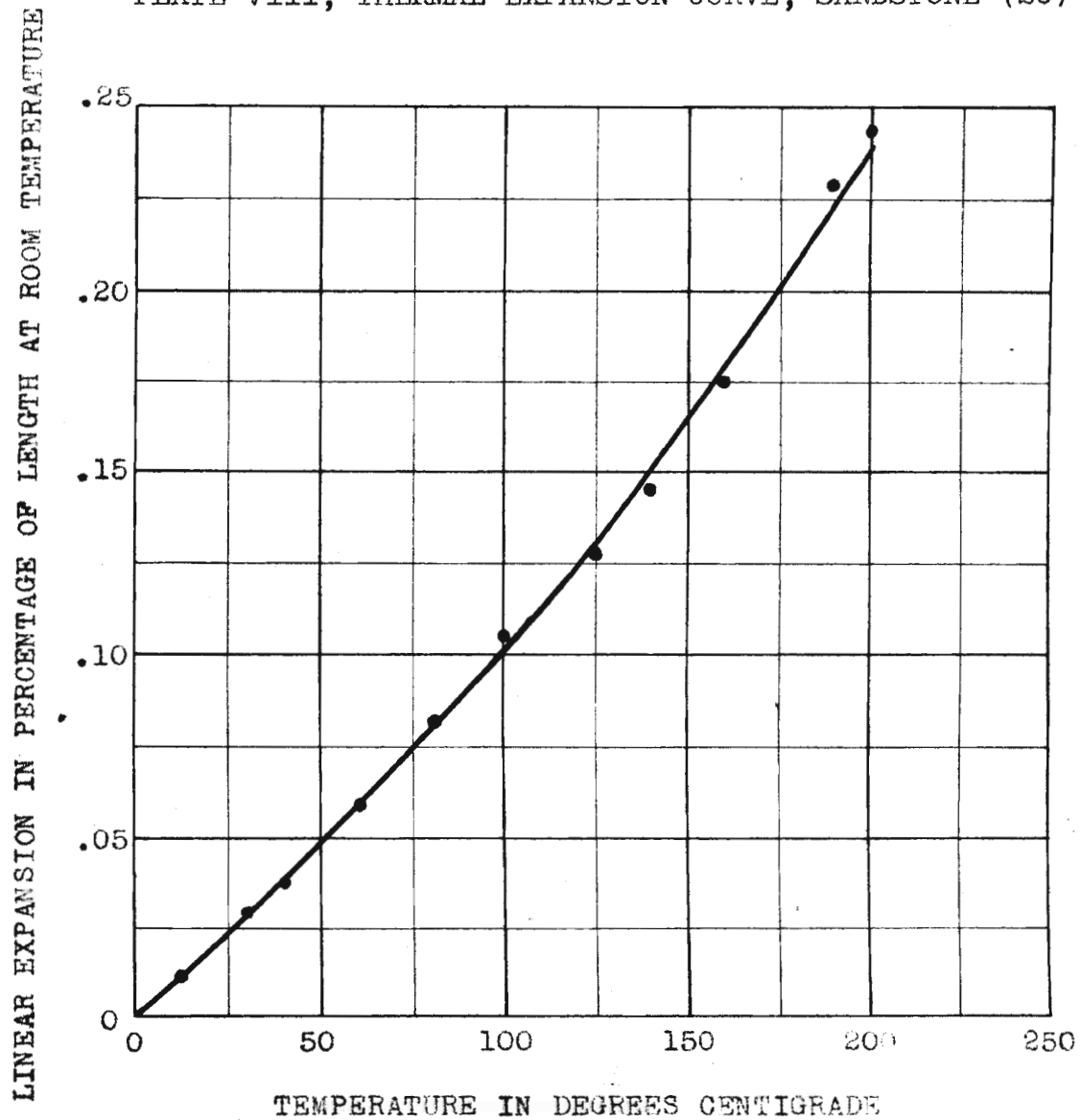

Expansion coefficient 0 to 100 Deg.C. = 10.62×10^{-6}

Expansion coefficient 100 to 200 Deg.C. = 13.86×10^{-6}

PLATE IX, THERMAL EXPANSION CURVE, SHALE (22)

LINEAR EXPANSION IN PERCENTAGE OF LENGTH AT ROOM TEMPERATURE

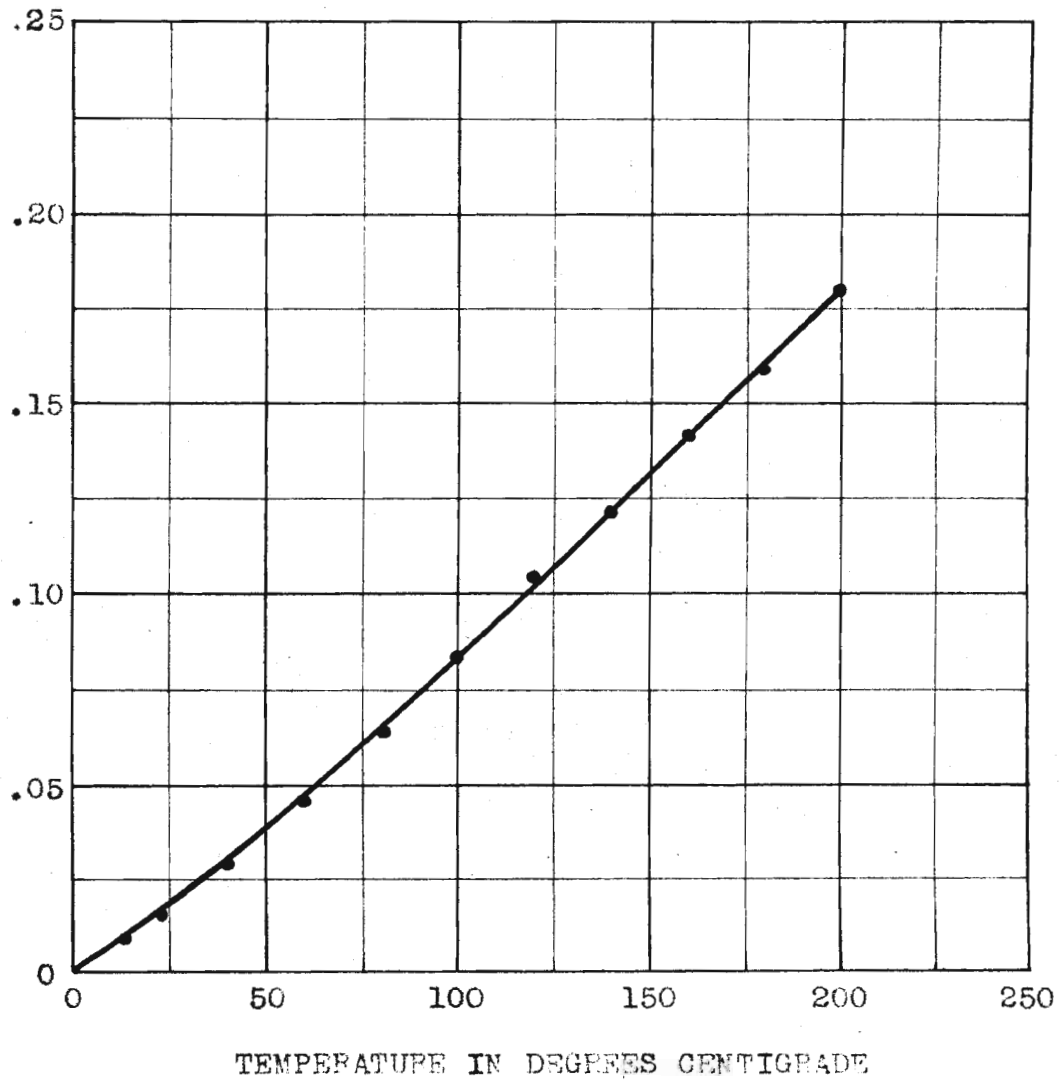

Expansion coefficient 0 to 100 Deg.C. = 8.36×10^{-6}

Expansion coefficient 100 to 200 Deg.C. = 9.53×10^{-6}

PLATE X, THERMAL EXPANSION CURVE, GRANITE (23)

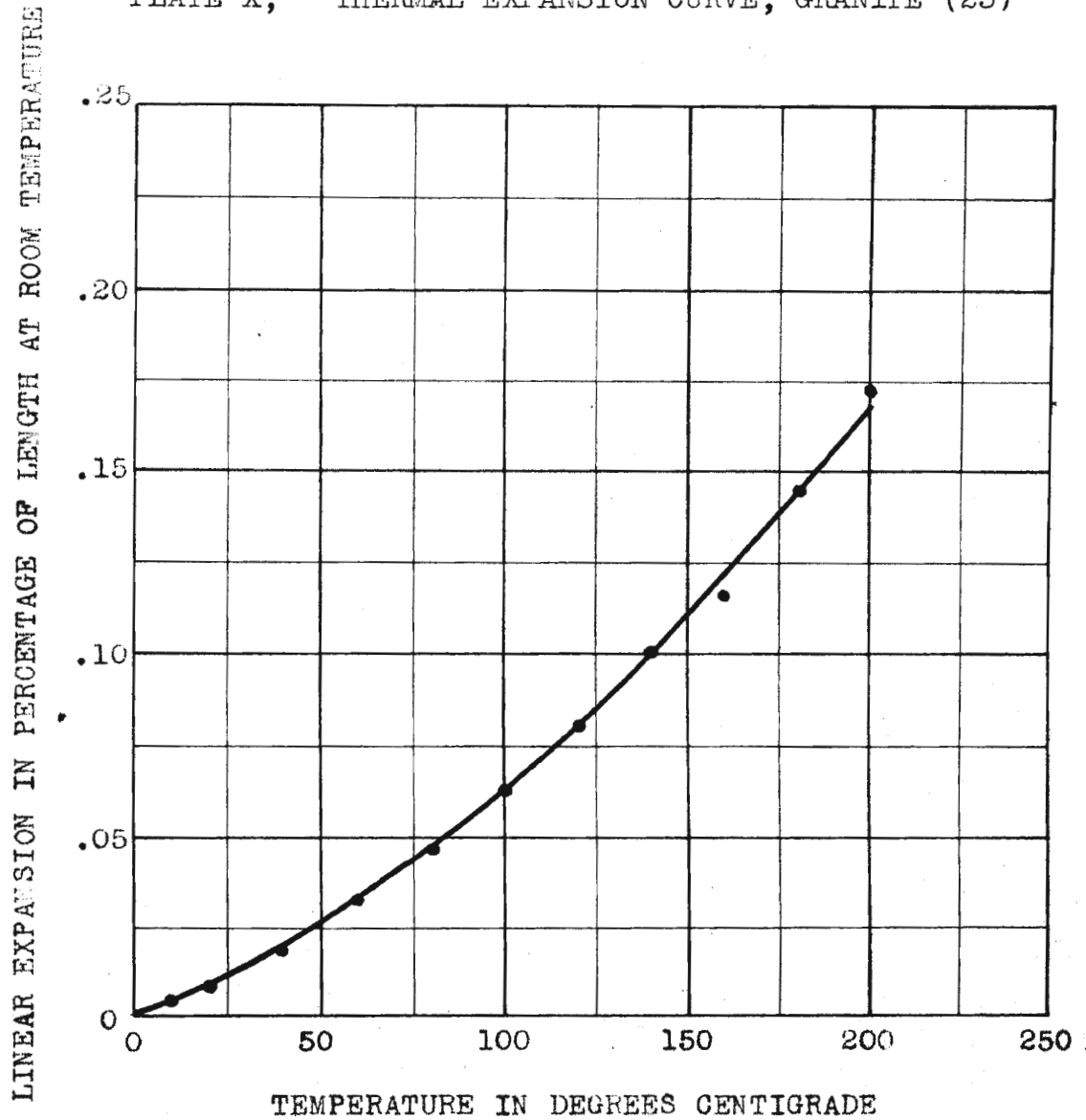

Expansion coefficient 0 to 100 Deg.C. = 6.27×10^{-6}

Expansion coefficient 100 to 200 Deg.C. = 11.03×10^{-6}

PLATE XI, THERMAL EXPANSION CURVE, PORPHYRY (24)

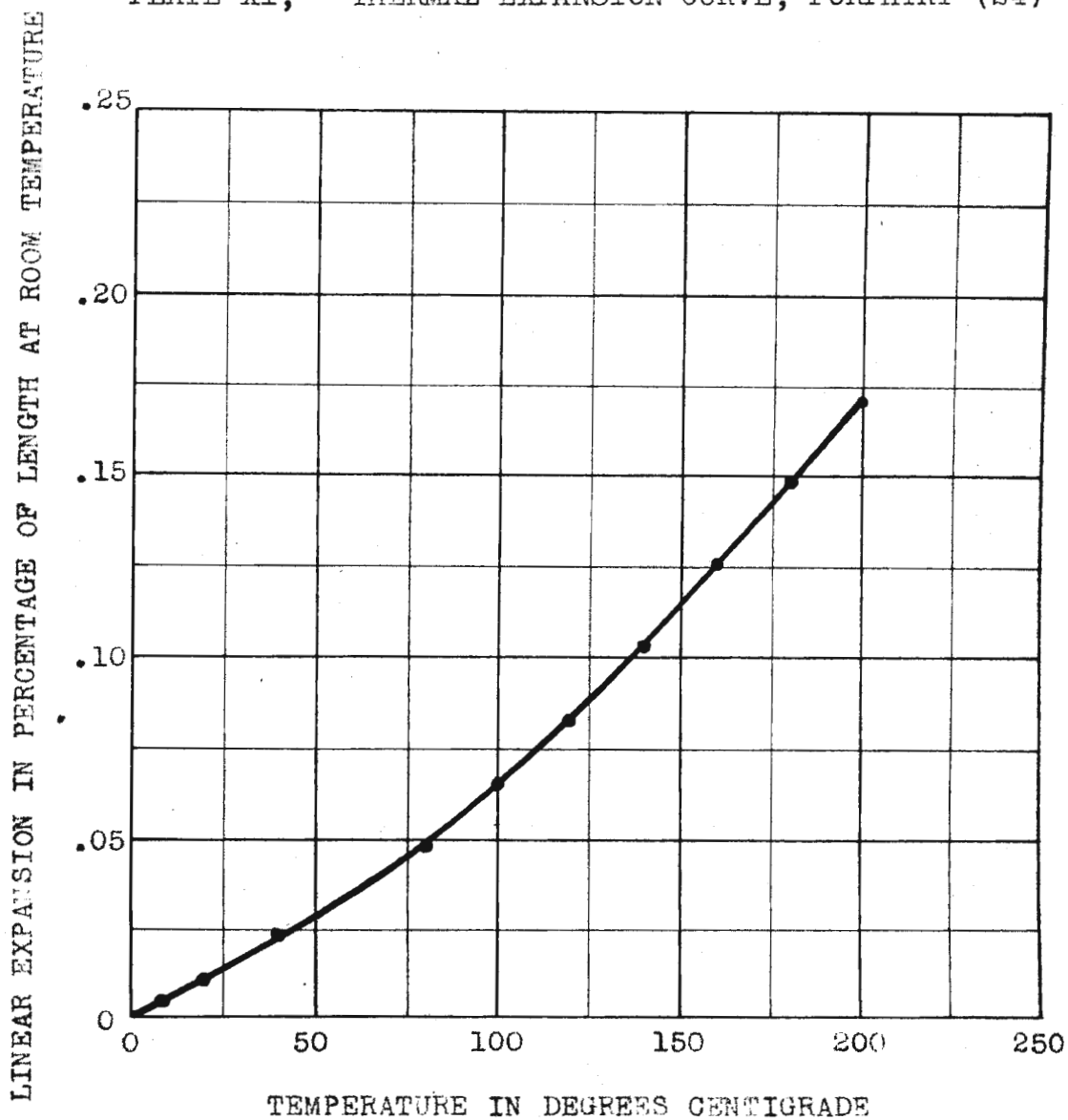

Expansion coefficient 0 to 100 Deg.C.= 6.52×10^{-6}

Expansion coefficient 100 to 200 Deg.C.= 10.62×10^{-6}

DETERMINATION OF THE PERCENT PERMANENT ELONGATION

A second type of test is made to determine the permanent elongation or the permanent swelling that results from successive heating and cooling of the rock. On a second specimen of each sample, which is prepared in the same manner that the specimens are prepared for the expansion tests, three consecutive heating and cooling tests are made through a temperature range, room temperature (23 Deg. C.) to 200 Deg. C.

^{10/} Hallock, as before noted, found that different rocks after being

^{10/} Hallock, op.cit.

heated to 100 Deg. C. and allowed to cool did not contract to their original length and that consecutive heating and cooling resulted in continuing but ever diminishing increments of lengths at ordinary temperatures.

^{11/} Wheeler states:

^{11/} Wheeler, op.cit. p. 44

"As the particles of the rock which have a smaller coefficient of expansion are torn apart by others having a greater expansion, more or less of a rearrangement of the loosened particles would naturally follow so that on cooling, instead of resuming their original position, they would tend to tear apart the crystals having the greater expansion coefficients. This would cause a weakening of the rock and a permanent elongation."

^{12/} According to Sosman, if the grains in a rock are not oriented alike,

^{12/} Sosman, R. B., The Properties of Silica. American Chemical Society, Monograph No. 37. Chemical Catalog Co., Inc., New York. 1927. p. 368

and open spaces will, as a result, be developed in the rock. When the rock is heated and again cooled, these openings will tend to close but these grains will never quite retrace their first movements and, as a result, some space will remain unfilled. Hence, there will be a permanent increase

in the length of the rock only in that dimension in which the measurements are being taken. When the rock is heated a second time the tendency will be for the grains to retrace the previous path of movement, but that there will also be a small amount of new differential movement which is not as large as that of the first heating. Sosman also explains that the curves platted from the data obtained from these consecutive heating and cooling tests may lay exactly parallel to the first curve and that they may run above or below it.

Permanent Elongation Tests

Each specimen was heated from room temperature (23 Deg. C.) to 200 Deg. C. and allowed to cool to room temperature again for three consecutive times. The test procedure is the same as that described above for the thermal expansion tests.

The objective of these tests is to determine approximately the amount of permanent elongation in a rock that can be expected from repeated changes of temperature. The results of the tests made are platted in graphical form (Plate XIII). The percent of permanent elongation for each heating and cooling cycle is platted as the ordinate and the number of heatings is platted as the abscissa.

Results

All the samples tested show a permanent increase in length with the exception of shale (sample 22) which shows a decrease in length. For convenience the results from sample 22 are platted as positive values in Plate XII.

The two limestone samples (17 and 18) show the greatest permanent elongation, and have a relatively high increase in length after the initial

PLATE XII, PERMANENT ELONGATION CURVES

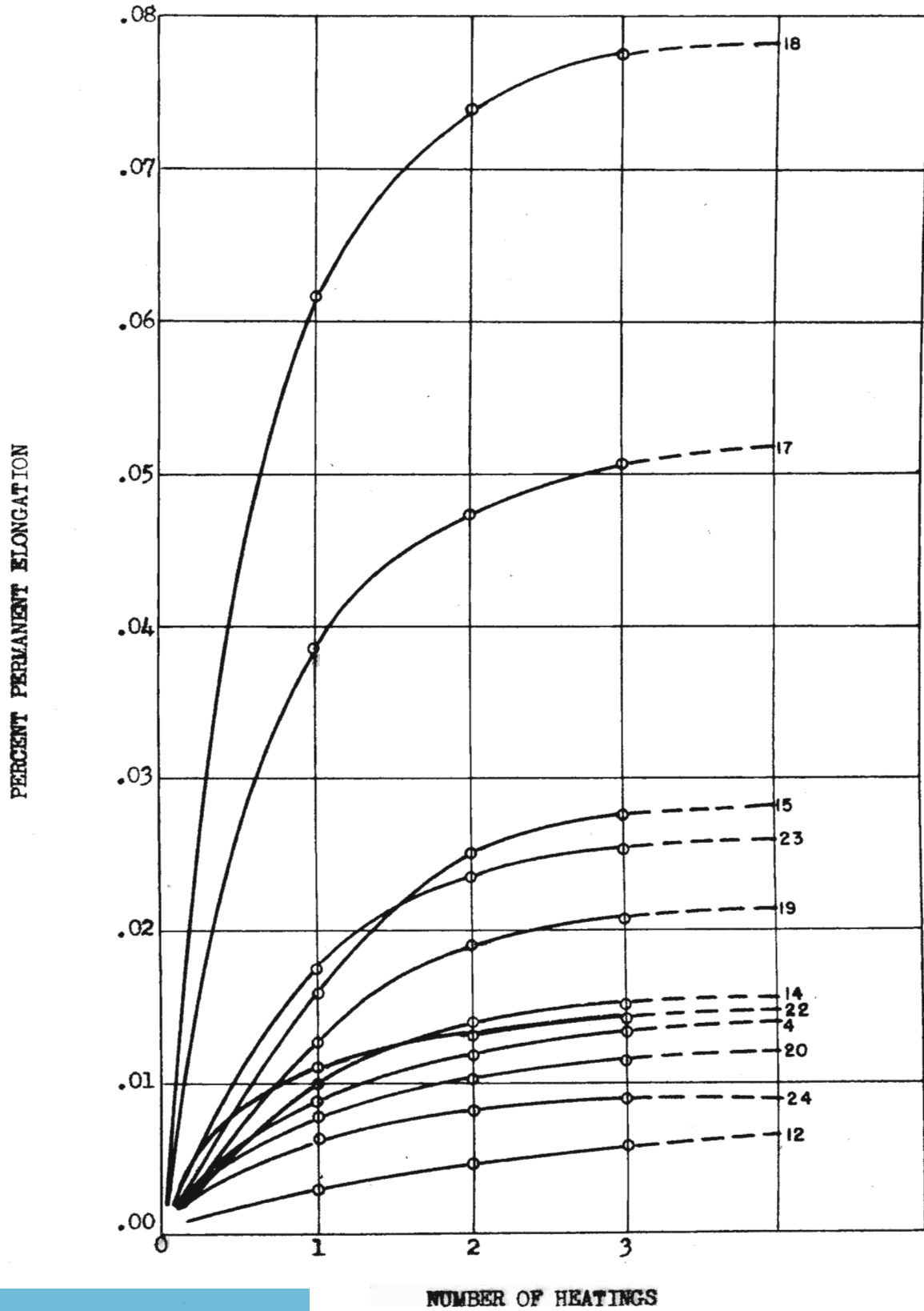

heating and cooling cycle, 0.062 percent increase for sample 18 and 0.038 percent increase for sample 17.

The sandstone samples (4, 12, and 20), as shown in Plate XII, have the least permanent elongation. The remaining samples, dolomites, granite, porphyry, and shale are in an intermediate range of permanent elongation, but the total elongation of each is nearly one-half as much as that of the limestones.

According to the theories cited above as to the movement of individual grains within a rock due to a temperature increase, limestones consisting of approximately 100 percent calcite have the greatest amount of movement of the individual grains, while the sandstones that consist mainly of silica have the least amount of individual grain movement. Therefore, limestones should suffer more internal fractures than the sandstones or other rock whose percent of permanent elongation is less than that of limestone.

It is also shown in Plate XII that the dolomites (samples 14, 15 and 19) are within the intermediate range of percent permanent elongation. The dolomites may not be pure dolomites and may contain some calcite grains in an amount large enough to effect the percentage of permanent elongation.

DETERMINATION OF POROSITY

The object of this part of the investigation is to determine the percentage porosity of various samples of rock to see if any relationship can be established between the percent porosity of a rock and the thermal expansion or percent permanent elongation.

^{13/}Dane believes that upon thermal treatment of a rock, the increment

^{13/} Dane, E. B., Density at high temperature; thermal expansion, Handbook of Physical Constants. Geological Society of America Special papers No. 36. 1942. pp. 28-29.

of change in length is represented by a change in the porosity of the specimen. He is quoted in part as follows:

"...when a rock is heated the grains with the largest thermal dilation tend to determine the apparent change of length of the whole specimen, creating internal fractures and 'pores'. Thus what is actually measured is rather the increase in porosity than the true thermal expansion...Most changes of conditions within the earth proceed slowly so that there is ample time for recrystallization to relieve the points of greatest stress and thus close the pores. However, the fact that all rocks have some porosity, which can be largely eliminated by about 1000 atmospheres of pressure, indicates that such readjustments and compensations are not complete."

Porosity is defined as the percentage of volume that the pore space bears to the bulk volume of the sample. Absolute porosity is the percentage that the total pore space bears to the bulk volume. Effective porosity is a term applied to that portion of the pore space that is continuous and yields to drainage influences. Often a part of the original pore space is isolated by compaction or secondary cementing material so that fluids may not penetrate from the outside or imprisoned fluids may not escape without actual disintegration of the sample. In this investigation effective porosity has been measured.

Test Procedure

Numerous methods have been devised for the determination of the percent porosity of a rock, but the method used in this investigation was suggested to the writer by Mr. F. A. Graser*. It is a simple and accurate

* Personal communication from Mr. F. A. Graser, Associate Professor of Petroleum Engineering, Missouri School of Mines and Metallurgy, Rolla, Missouri.

procedure combining the gravimetric and pycnometer methods.

Four specimens are cut from each sample of rock. Two of these specimens are cut from a rock which had been tested for permanent elongation, being heated and cooled three consecutive times. The remaining two specimens are cut from the fresh sample adjacent to the position where the samples were cut for the temperature tests.

The test procedure is as follows:

- (1) Weigh a pycnometer type flask dry after it has been heated to a temperature of 97 Deg. C. and allowed to cool to room temperature in a desiccator.
- (2) Fill this flask with distilled water (which has been previously boiled for 20 minutes and allowed to cool to room temperature) and weigh.
- (3) Knowing the density of water at room temperature (in these tests room temperature is 26 Deg. C.) the volume of the flask can be determined.
- (4) Clean and dry the flask again.
- (5) Fill the flask with tetrachloroethane at room temperature and weigh.
- (6) The weight of the tetrachloroethane from step (5) is then divided by the volume of the flask, step (3), and this quotient is the density of the tetrachloroethane at room temperature.
- (7) Weigh the specimen, which has been dried and allowed to cool to room temperature in a desiccator.
- (8) Place the specimen in a shallow cup filled with tetrachloroethane at room temperature so that the sample is totally immersed. Then place the cup with the sample under a vacuum of 25 in. of Hg. using a bell jar and a vacuum pump. The pressure inside the bell jar is allowed to become atmospheric four times during the eight hour period.

- (9) Weigh the saturated sample after carefully blotting the excess tetrachloroethane from the surface of the sample.
- (10) Determine the volume of the tetrachloroethane absorbed in the rock by dividing the difference between the weights found in step (9) and step (7) by the density of the tetrachloroethane.
- (11) Place the saturated specimen in the pycnometer type flask and fill the remaining volume of the flask with tetrachloroethane, at room temperature, and weigh.
- (12) The weight of the tetrachloroethane displaced is then determined by finding the difference between the weight obtained in step (5) and the difference in weight of step (11) and step (9).
- (13) The volume of the tetrachloroethane displaced is determined by dividing the value for step (12) by the density of the tetrachloroethane.
- (14) The percent pore space of the rock is then determined by dividing the value found in step (10) by that of step (13) and multiplying by 100.

The following equations are used to calculate the percent porosity:

$$1) \frac{(W_{fw} - W_f)}{D_w} = V_1$$

$$2) \frac{(W_{ft})}{V_1} = D_t$$

$$3) W_2 - W_1 = W_3$$

$$4) W_{ft} - (W_4 - W_2) = W_5$$

$$5) \frac{W_3}{D_t} \div \frac{W_5}{D_t} \times 100 = \frac{W_3}{W_5} \times 100 = \text{percent porosity}$$

W_1 = weight of dry specimen

W_2 = weight of saturated specimen

W_3 = weight of tetrachloroethane absorbed

W_f = weight of the dry flask

W_{fw} = weight of flask filled with water

- W_{ft} = weight of flask filled with tetrachloroethane
 W_4 = weight of flask, solution, and saturated specimen
 D_t = density of tetrachloroethane
 D_w = density of water
 W_5 = weight of solution displaced by saturated specimen
 V_1 = volume of the flask

Results

All the samples of rock tested have some porosity, however, samples 14, 18, 23, and 24 have less than one percent.

Two of the sandstones (samples 4 and 12) show an increase in porosity, 0.88 percent and 1.30 percent respectively, in the specimens that have been heated, however, sample 20 shows a decrease in porosity of 0.94 percent.

Two of the dolomites (samples 14 and 15) show a decrease in porosity, 0.14 percent and 1.33 percent respectively, in the specimens that have been heated, while sample 19 shows an increase in porosity of 0.85 percent.

The two limestones vary considerably. Both the heated and the fresh samples increased in porosity; sample 17 increased 0.84 percent, and sample 18 increased 0.21 percent.

The shale (sample 22) shows an increase in porosity in the specimens that have been heated of 0.44 percent.

The granite (sample 23) shows a small initial porosity of 0.72 percent in the fresh rock and a slight decrease in the heated specimen, 0.68 percent, which can be considered negligible. The porphyry (sample 24) shows a small initial porosity of 0.49 percent in the fresh rock, and no change in porosity in the heated specimen.

It can be seen from the results shown in Table IV that apparently consecutive heating and cooling, as suggested by Dane, does have an effect on the porosity of a rock. From the results obtained in this study, however,

Table IV
Data Sheet for Porosity Tests

Spl. No.	Dry Weight	Saturate Weight	Absorbed Wt. Sol.	W ₄ (gm.)	W ₅ (gm.)	Porosity %
	W ₁ (gm.)	W ₂ (gm.)	W ₃ (gm.)			
I	II	III	IV	V	VI	VII
4a ₁	4.3786	4.8538	0.4752	74.4518	3.0731	15.46
4a ₂	5.2761	5.8337	0.5576	74.8720	3.6328	15.34
4b ₁	4.9945	5.4962	0.5057	74.7059	3.4709	14.58
4b ₂	4.2583	4.6865	0.4282	74.3973	2.9613	14.45
12a ₁	5.3776	5.8832	0.5156	74.8928	3.6715	14.04
12a ₂	4.8608	5.3274	0.4666	74.6059	3.2926	14.17
12b ₁	5.0159	5.4435	0.4276	74.7624	3.3522	12.75
12b ₂	5.6594	6.1598	0.5004	74.9419	3.8890	12.86
14a ₁	5.5704	5.5901	0.0197	75.1571	3.1041	0.63
14a ₂	5.5120	5.5408	0.0208	75.0861	3.1178	0.66
14b ₁	5.1706	5.1969	0.0263	74.8720	3.0960	0.84
14b ₂	5.8668	5.8921	0.0253	75.1525	3.4107	0.74
15a ₁	6.4869	6.8297	0.3428	75.5300	3.8708	8.85
15a ₂	6.4250	6.7602	0.3352	75.5398	3.8915	8.61
15b ₁	5.6077	5.9570	0.3493	75.1677	3.4604	10.12
15b ₂	5.4906	5.8200	0.3294	75.1945	3.2966	9.99
17a ₁	4.9581	5.0246	0.0665	74.7878	2.9079	2.28
17a ₂	5.0150	5.0827	0.0677	74.7539	2.9999	2.25
17b ₁	6.0825	6.1500	0.0721	75.3050	3.5207	2.04
17b ₂	5.7022	5.7670	0.0648	75.0868	3.3513	1.93
18a ₁	6.3157	6.3441	0.0284	75.3000	4.6152	0.62
18a ₂	6.7495	6.7791	0.0296	75.4170	4.0332	0.73
18b ₁	5.9049	5.9204	0.0155	75.1279	3.4638	0.45
18b ₂	5.7629	5.7779	0.0128	75.6742	2.7876	0.46
19a ₁	5.7961	5.9367	0.1396	75.2139	3.3929	4.11
19a ₂	5.7919	5.9308	0.1389	75.2234	3.3785	4.10
19b ₁	5.6543	5.7695	0.1152	75.0966	3.3440	3.44
19b ₂	5.7239	5.8350	0.1011	75.2100	3.2861	3.08
20a ₁	5.3805	5.6088	0.2283	74.8148	3.4651	6.58
20a ₂	5.3052	5.5229	0.2177	74.8080	3.4060	6.39
20b ₁	5.7461	6.0129	0.2669	75.1041	3.5799	7.45
20b ₂	5.8599	6.1340	0.2741	75.0207	3.7844	7.24
22a ₁	4.8235	5.0055	0.1820	74.7275	2.9491	6.17
22a ₂	5.6770	5.8787	0.2017	75.1632	3.3866	5.96
22b ₁	5.0190	5.1896	0.1706	74.7935	3.0672	5.56
22b ₂	4.4196	4.5686	0.1490	74.5790	2.6807	5.55

(con't.)

Table IV con't.

Spl. No.	Dry	Saturate	Absorbed			Porosity %
	Weight W ₁ (gm.)	Weight W ₂ (gm.)	Wt. Sol. W ₃ (gm.)	W ₄ (gm.)	W ₅ (gm.)	
I	II	III	IV	V	VI	VII
23a ₁	6.0799	6.1044	0.0245	75.1894	3.5861	0.68
23a ₂	6.2491	6.2740	0.0249	75.2311	3.7140	0.67
23b ₁	6.6960	6.7246	0.0286	75.3680	4.0277	0.71
23b ₂	5.1106	5.1320	0.0214	74.8519	2.9512	0.72
24a ₁	4.9544	4.9697	0.0153	74.6663	2.9745	0.51
24a ₂	4.9824	4.9957	0.0133	74.6742	2.9927	0.46
24b ₁	5.4235	5.4396	0.0161	74.8588	3.2519	0.49
24b ₂	5.0946	5.1174	0.0149	74.7505	3.0303	0.49

* Subscript a denotes heated specimen; subscript b denotes fresh specimen.

porosity does not increase in all of the samples subjected to heating, but that some have a definite decrease in porosity.

The effect of a high initial porosity on the coefficient of thermal expansion is shown by comparing the average values for the percent porosity of a fresh sample with the values for the expansion coefficients. Those rocks with high initial porosity have the high coefficients of expansion, and the rocks with low initial porosity have the lowest coefficient of expansion.

DETERMINATION OF PERMEABILITY

The object of this part of the investigation is to determine the permeability of the samples in an effort to find a relationship between permeability and thermal expansion or permanent elongation.

The permeability of a rock is a measure of the resistance offered by it to the movement of fluids through its pore spaces. The standard unit of permeability as defined by the American Petroleum Institute ^{14/} is the

^{14/} Standard procedure for determining permeability of porous media.
American Petroleum Institute Code No. 27. 2d ed. 1942. p.4

"darcy". The "darcy" is defined as a measure of the rate of flow in milliliters per second, of a fluid of one centipoise viscosity through a cross section of one square centimeter of a porous medium, under a pressure gradient of one atmosphere (76.0 cm. of Hg) per centimeter and conditions of viscous flow.

Permeability may be computed just as well when the data which are obtained result from a flow of gas as when the fluid is a homogeneous liquid. The only requirements are accuracy, reliable data, the use of the appropriate equation and physical and chemical inertness of the medium to both fluids.

The fluid used in these tests was air. The equation used to determine permeability is given on page 42.

Permeability Tests

A piece of each sample of rock is first saturated with water in order to cut down the disintegration of the cementing material before cutting the specimens to a desired size (approximately 1-inch long with a 3/8 in. cross section).

Each specimen is first dried in an oven and then placed in a desiccator. After the temperature of the specimens has reached room temperature, the dimensions of each are measured with a micrometer reading to 0.001 in. These dimensions are converted to measurements of the metric system and are recorded.

Each specimen is then placed in a small steel cylinder (1 in. diameter and 1 3/8 in. long) and sealing wax is poured around the specimen. The end faces of the specimen are all that are exposed. The small steel cylinder is the part of the permeameter that holds the specimen (Figure 4).

The apparatus for measuring permeability is described below and illustrated in Figure 4.

- (a) A device (F) for holding the specimen to be tested.
- (b) Manometers for measuring the pressure of the fluid at the inlet (E) and outlet (I) faces of the sample.
- (c) Suitable devices (C) to control the inlet pressure and the rate of flow.
- (d) A low-pressure meter (H) for measuring the volume of fluid forced through the specimen and a thermometer to measure the temperature of the flowing fluid.
- (e) A filter (B) to dry the air supply and to remove solids.
- (f) A stop watch.
- (g) A micrometer to measure the dimensions of the specimen.
- (h) A barometer.

The steps of the procedure are as follows:

- (1) Place the prepared specimen, as described above, in the permeameter.
- (2) Open the control valve and adjust the pressure control manifold to an inlet pressure of 14.55 in. of Hg measured with the differential gage. The value of 14.55 in. of Hg inlet pressure is selected because it is just below the pressure of one-half atmosphere, 14.96 in. of Hg, which was computed as the minimum pressure for turbulent flow for the average cross sectional area of the specimens.

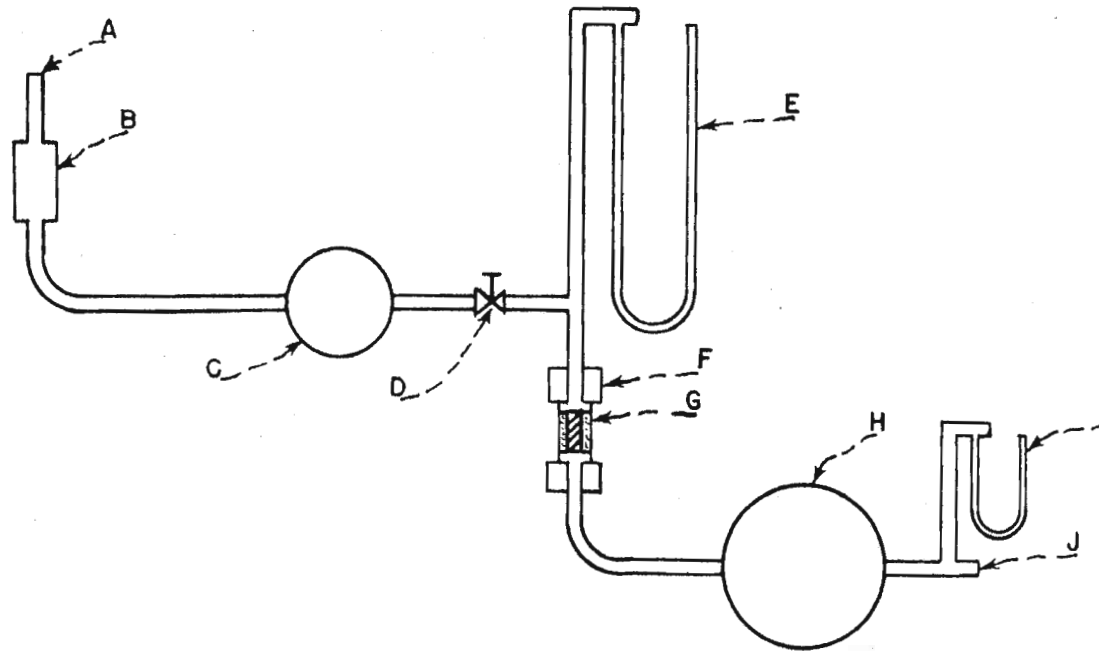

- | | |
|---|--------------------------------|
| A. Compressed air supply | F. Permeameter |
| B. Filter (calcium chloride and glass wool) | G. Mounted specimen |
| C. Pressure control manifold | H. Wet-test low-pressure meter |
| D. Control valve | I. Manometer (inches of water) |
| E. Differential gage (inches of Hg) | J. Discharge opening |

Figure 4 -- SCHEMATIC DIAGRAM OF PERMEABILITY TESTING APPARATUS

- (3) The time limit for each run is 1,500 seconds unless, the time required to pass 0.01 cu. ft. of air through the specimen is less than 1,500 seconds.
- (4) After the time limit, the specimen is inverted and a second run is made, again as described in steps (1), (2), and (3).

The following readings were taken and recorded in Table V:

- (a) The volume of air that passed through the specimen.
- (b) The time, in seconds, that a quantity of air took to pass through the specimen.
- (c) Inflow pressure, inches of Hg.
- (d) The outflow pressure, inches of water.
- (e) Barometric pressure, inches of Hg.
- (f) The temperature of the outflow air.
- (g) Dimensions of the specimen.

The amount of permeability measured in millidarcys is computed from the data accumulated in Table V, and from the equation below which provides a direct expression for permeability for experimental purposes.^{15/}

15/ op.cit. p.9

$$K = \frac{2 u Q_b P_b L}{A (P_1^2 - P_2^2)}$$

In which:

- K = permeability of the medium; darcys (K x 1000 = millidarcys).
- u = (Mu): viscosity of fluid; centipoises (determined from tables, knowing the temperature of the air).
- Q_b = volume rate of flow measured at base pressure, P_b; milliliters per second.
- P_b = base pressure; atmospheres (absolute).
- L = length; centimeters.
- A = the cross sectional area of the medium perpendicular to the line of flow; square centimeters.

P_1 = upstream (greater) pressure; atmospheres (absolute).

P_2 = downstream (smaller) pressure; atmospheres (absolute).

In these tests the difference between the inflow and outflow pressures of the meter was negligible when measured with a water manometer. Therefore, it can be considered that the pressure base, P_b , for measuring the quantity of air, Q_b , passing through the meter is the atmospheric pressure as taken from the barometer. Hence, P_2 is equal to P_b .

Results

Of all the samples tested only two samples (4 and 12) show permeability within the limitations of the test procedure described above. Sample 4 has an average permeability of 1030.0 millidarcys, and sample 12 has an average permeability of 129 millidarcys.

The remaining samples show no permeability, therefore no relationship between thermal expansion or permanent elongation and permeability can be established in this study.

Table V
Data Sheet for Permeability Tests

Sample	Volume of air at atmos. pres. Cu. Ft.	Time (Sec.)	Inflow Pressure (In.Hg.)	Outflow Pressure (In.Hg.)	Barometric Pressure (mm.Hg.)	Flowing Temp. of air (°C.)	Viscosity of air $\frac{\mu}{u}$	Cross-Sect. area (Sq.Cm.)
1	2	3	4	5	6	7	8	9
4	0.01	212	14.55	0.0	734.0	25	0.1832	0.926
4	0.01	218	14.55	0.0	734.0	25	0.1832	0.926
12	0.01	1563	14.55	0.0	734.0	25.6	0.18349	0.998
12	0.01	1441	14.55	0.0	734.0	26.7	0.18354	0.998
14	0.00	1500	14.55	0.0	734.0	---	-----	0.813
14	0.00	1500	14.55	0.0	734.0	---	-----	0.813
15	0.00	1500	14.55	0.0	721.7	---	-----	0.916
15	0.00	1500	14.55	0.0	721.7	---	-----	0.916
17	0.00	1500	14.55	0.0	721.7	---	-----	1.106
17	0.00	1500	14.55	0.0	721.7	---	-----	1.106
18	0.00	1500	14.55	0.0	721.7	---	-----	0.871
18	0.00	1500	14.55	0.0	721.7	---	-----	0.871
19	0.00	1500	14.55	0.0	721.7	---	-----	0.863
19	0.00	1500	14.55	0.0	721.7	---	-----	0.863
20	0.00	1500	14.55	0.0	721.7	---	-----	1.003
20	0.00	1500	14.55	0.0	721.7	---	-----	1.003
22	0.00	1500	14.55	0.0	721.7	---	-----	0.957
22	0.00	1500	14.55	0.0	721.7	---	-----	0.957
23	0.00	1500	14.55	0.0	721.7	---	-----	0.864
23	0.00	1500	14.55	0.0	721.7	---	-----	0.864
24	0.00	1500	14.55	0.0	721.7	---	-----	0.986
24	0.00	1500	14.55	0.0	721.7	---	-----	0.986

Length	Q_b (ml/sec. at Pres. P_b)	Inflow \neq Barometric Pressure (In.Hg.)	Outflow \neq Barometric Pressure (In.Hg.)	P_1 Upstream Pres. Col. 12 \div 29.92 (atm.)	P_2 Downstream Pres. Col. 13 \div 29.92 (atm.)	P_b Pressure (atm.)	Permeability Millidarcys
10	11	12	13	14	15	16	17
2.609	1.336	44.50	28.950	1.4873	0.9676	0.9676	1050.0
2.609	1.299	44.50	28.950	1.4873	0.9676	0.9676	1020.0
2.451	0.1811	44.50	28.950	1.4873	0.9676	0.9676	124.0
2.451	0.1965	44.50	28.950	1.4873	0.9676	0.9676	134.0
2.297							
2.297							
2.431							
2.431							
2.400							
2.400							
2.326							
2.326							
2.427							
2.427							
2.446							
2.446							
2.471							
2.471							
2.463							
2.463							
2.498							
2.498							

CONCLUSIONS

This thesis presents the results of an investigation made to determine the coefficients of thermal expansion, the percent of permanent elongation, the percent of porosity, and the permeability of eleven samples of rock. The tabulated results are given in Table VI.

The coefficients of lineary thermal expansion were determined in the planes of natural bedding of the rocks when the specimens were heated in an electric furnace through a range of 200 Deg. C. (360 Deg. F.). The specimens were approximately 8 in. long and $\frac{3}{8}$ by $\frac{3}{8}$ in. cross section (20 cm. by 1 cm. by 1 cm.). The coefficient of expansion varied from a maximum of 10.62×10^{-6} (C.) for sandstone to a minimum of 6.27×10^{-6} (C.) for granite within the range 0 to 100 Deg. C., and from a maximum of 14.95×10^{-6} (C.) for limestone to a minimum of 9.48×10^{-6} (C.) for shale within the range 100 to 200 Deg. C.

The expansions appear to be high for those rocks containing a maximum amount of free silica and low for those rocks containing combined silica or for those having essentially no silica.

In the tests to determine the permanent elongation each specimen was heated to 200 Deg. C. and allowed to cool to room temperature three consecutive times. The dimensions of the specimens were approximately the same as those described above for the thermal expansion tests. The percent permanent elongation has been platted against the number of heatings to show the tendency of the rocks to approach a permanent state and also to show the relative permanent elongation of the samples to each other.

The determination of the percent porosity of each rock, both before and after heating, was made to see if a relationship exists between the porosity and the coefficient of expansion or the permanent elongation. The percent porosity was found by the use of a procedure that combines the

gravimetric and the pycnometer methods of determining porosity. As previously stated, Dane suggested that what actually is measured is an increase in porosity rather than the true thermal expansion of a rock when it is heated.

The results of the porosity tests showed that in most samples there was a change in porosity due to the effect of heating, but these changes were represented by both an increase and a decrease in porosity. The sandstone (sample 4) had the highest porosity of all the samples, 14.52 percent; the porphyry (sample 24) had the least porosity, 0.49 percent.

The determination of the amount of permeability for each sample was carried out in order that a relationship between the coefficient of expansion or the permanent elongation and the permeability might be proved. The results were inconclusive as only two samples showed permeability: sample 4 had a permeability of 1,030 millidarcys; and sample 12 had a permeability of 129 millidarcys. The procedure used to determine the permeability of the samples was one that is outlined by the American Petroleum Institute.

The effect that thermal expansion can have on a roof composed of one of these types of rock is quite small. Assume that an exposure in an excavation is 3 meters wide and that the temperature of the roof rock is raised 10 Deg. C. If the exposed rock is a dolomite (sample 14) the total lateral expansion would be 0.024 cm. (approximately 0.01 in.). But if the temperature is raised and lowered successively over a period of time, the rock in the roof will expand an additional increment of length after each cycle of heating until a permanent state is approached, or perhaps the rock will eventually fracture thereby weakening the roof which at a later time may result in a fall of a portion of the roof rock.

Table VI
Tabulated Results of this Investigation

Type of Rock	No.	Coef. of Ther. Exp. (C.) multiply by 10^{-6}		Ave. Porosity (percent)	
		Range 0° to 100°C.	Range 100° to 200°C.	Heated Spec.	Fresh Spec.
Sandstone	4	10.39	14.18	15.40	14.52
Sandstone	12	9.36	11.54	14.10	12.81
Sandstone	20	10.62	13.68	6.49	7.35
Dolomite	14	8.00	11.64	0.65	0.79
Dolomite	15	9.80	12.80	8.73	10.06
Dolomite	19	8.28	10.12	4.11	3.26
Limestone	17	6.62	12.93	2.26	1.98
Limestone	18	8.80	14.95	0.67	0.46
Shale	22	8.38	9.48	6.07	7.35
Granite	23	6.27	11.03	0.68	0.72
Porphyry	24	6.52	10.60	0.49	0.49

	Permanent elongation (percent)			Permeability (Millidarcys)
	eating	2d heating	3d heating	
091		0.0122	0.0137	1030.0
026		0.0043	0.0052	129.0
083		0.0104	0.0117	--
102		0.0140	0.0152	--
160		0.0255	0.0275	--
130		0.0191	0.0207	--
386		0.0470	0.0506	--
620		0.0743	0.0775	--
115		-0.0135	-0.0145	--
177		0.0237	0.0255	--
063		0.0079	0.0090	--

APPENDIX A

DESCRIPTION OF ROCKS TESTED

The rock descriptions that follow are the result of a microscopic examination with a hand lens.

Lamotte Sandstone (sample #4)

A buff to red colored, firable, medium-grained rock, composed of angular quartz grains with a siliceous cementing material.

Lamotte Sandstone (sample #12)

A light buff colored, compact, fine-grained rock, composed of fine angular quartz grains with included well-rounded chert granules.

Bonne Terre Dolomite (sample #14)

A light-green colored, conglomeratic dolomite.

Carthage Limestone (sample #17)

A white to light-gray colored rock consisting of varied sizes of calcite crystals and cemented with fine-grained calcite.

Jefferson City Dolomite (sample #15)

A dark-gray colored, medium-grained, cherty dolomite; the stringers of chert closely parallel the bedding planes. This rock is commonly called "cotton rock".

Burlington Limestone (sample #18)

A white to light-gray colored rock consisting of varied sizes of calcite crystals cemented with fine grained calcite. Some fossils are present.

Jefferson City Dolomite (sample #19)

A buff to gray, fine-grained dolomite.

Roubidoux Sandstone (sample #20)

A white, medium-grained rock with angular quartz grains cemented with

silica. The rock also contains some bands of quartzite.

Shale (sample #22)

A black, fine-grained, compact shale. This is a sample of shale from the top of the No. 6 Coal, West Frankfort, Illinois.

Granite (sample #23)

A holocrystalline white granite that is used principally as a building stone. The major minerals are feldspar and quartz. The most prominent minor mineral is biotite mica.

Porphyry (sample #24)

Small to medium-sized phenocrysts of red feldspar are dispersed through a dense black fine-grained groundmass.

BIBLIOGRAPHY

1. Books:

- a. Eckel, E. C., Building stones and clay. New York, John Wiley, 1912 pp. 201-203.
- b. Merrill, G. P., Stones for building and decoration. 3d ed. New York, John Wiley, 1891. pp. 354-357.
- c. Reis, H., Economic geology. 7th ed. New York, John Wiley, 1942. p. 107.
- d. Sosman, R. B., the properties of silica. American Chemical Society Monograph No. 37. New York. Chemical catalog co., 1927. pp. 360, 368, and 388.
- e. Whitney, M. O., and Ashton, J., Johnson's material of construction. 8th ed. New York, John Wiley, 1930. pp. 249-250.

2. Periodicals:

- a. McNary, H. B., Investigations of mine roof disintegration. Mining Congress Journal. Vol. 27, April, 1941. pp. 28-30.

3. Publications of Learned Societies:

- a. American Petroleum Institute. Standard procedure for determining permeability of porous media. Code No. 27, 2d ed. 1942. pp. 1-21.
- b. Dane, E. B., Density at high temperature; thermal expansion. In: Handbook of physical constants. Geological Society of America, Special papers No. 36. 1942. pp. 27-37.
- c. Wheeler, N. E., On the thermal expansion of rock at high temperature. Transactions of the Royal Society of Canada. 3d series, Vol. IV, 1910. pp. 19-44.

4. U. S. Government Publications:

- a. Hartman, I., and Greenwald, H. P., Effect of changes in moisture and temperature on mine roof. U. S. Bureau of Mines, Report of Investigations 3588. 1941. pp. 1-40.
- b. Souder, W. H., and Hidnert, P., Thermal expansion of insulating materials, U.S. Bureau of Standards, Scientific paper No. 352. 1919. pp. 1-23.

5. State Publications

- a. Buckley, E. R., Building and ornamental stones. Wisconsin Geological and Natural History Survey Bulletin IV. 1898. pp. 18-19.

- b. Griffith, J. H., Thermal expansion of typical American rocks. Iowa State College Engineering Experiment Station Bulletin 128. 1936. pp. 1-36.
- c. Westman, A. E. R., The thermal expansion of fireclay bricks. University of Illinois Engineering Experiment Station Bulletin 181. 1928. pp. 1-30.